

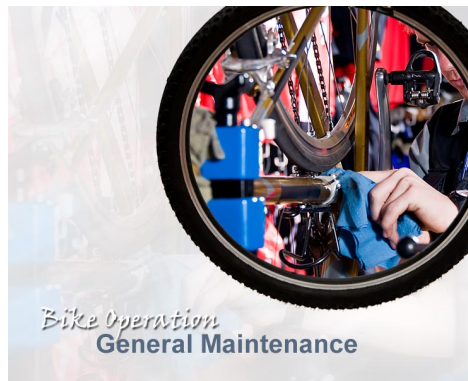

Manufacturer code: KD559

COMPONENT MAINTENANCE PUBLICATION

ATA CMP Text Book



Product

(NOTE: Refer to the Configuration table for detailed part number information)

TEST

Export control

Export of this data module to all countries that are the residence of organizations that are users of S1000D is permitted. Storage of this data module is to be at the discretion of the organization.

GB Export Classification :

S1000DBIKE-KD559-CMPXX-00

Issue No: 003

2018-03-01

Page TP-1

CTM23-10-10

Copyright (C) 2025 by Contiem Ltd

Regulatory

1. warning

WARNING

Utcunque enim varia sint genera politiarum, unicus est status scientiarum, isque semper fuit et mansurus est popularis. Probabiles enim tantum rationes secuti videntur, et argumentorum vertigine circumaguntur, et promiscua quaerendi licentia severitatem inquisitionis enervarunt.

Utcunque enim varia sint genera politiarum, unicus est status scientiarum, isque semper fuit et mansurus est popularis. Probabiles enim tantum rationes secuti videntur, et argumentorum vertigine circumaguntur, et promiscua quaerendi licentia severitatem inquisitionis enervarunt.

Utcunque enim varia sint genera politiarum, unicus est status scientiarum, isque semper fuit et mansurus est popularis. Probabiles enim tantum rationes secuti videntur, et argumentorum vertigine circumaguntur, et promiscua quaerendi licentia severitatem inquisitionis enervarunt.

Utcunque enim varia sint genera politiarum, unicus est status scientiarum, isque semper fuit et mansurus est popularis. Probabiles enim tantum rationes secuti videntur, et argumentorum vertigine circumaguntur, et promiscua quaerendi licentia severitatem inquisitionis enervarunt.

Utcunque enim varia sint genera politiarum, unicus est status scientiarum, isque semper fuit et mansurus est popularis. Probabiles enim tantum rationes secuti videntur, et argumentorum vertigine circumaguntur, et promiscua quaerendi licentia severitatem inquisitionis enervarunt.

Configuration

Table CONF-1 Support equipment

Name/Alternate name	Identification/Reference	MFR	Quantity	Remarks
N/A	N/A	N/A	N/A	N/A

Table CONF-2 Consumables, materials and expendables

Name/Alternate name	Identification/Reference	MFR	Quantity	Remarks
N/A	N/A	N/A	N/A	N/A

Table CONF-3 Spares

Name/Alternate name	Identification/Reference	MFR	Quantity	Remarks
N/A	N/A	N/A	N/A	N/A

BRAKE-AAA-DA1-00-00-00AA-341A-A

1. Brake Test

- Put the bicycle in a vertical position.
- 2. Hold the handle bars and push the bicycle forwards.
- 3. Apply the brakes.
- 4. Make sure that the wheels lock and the bicycle stops.

End of BRAKE-AAA-DA1-00-00-00AA-341A-A
End of CONFIGURATION

INTENTIONALLY BLANK

Copyright statements

S1000DBIKE-AAA-D00-00-00-00AA-021A-C

1. Copyright

Copyright (C) 2025 Contiem Ltd

- This material is provided "As is" and neither Contiem nor any person who has contributed to the creation, revision or maintenance of the material makes any representations or warranties, express or implied, including but not limited to, warranties of merchantability or fitness for any particular purpose.
- Neither Contiem nor any person who has contributed to the creation, revision or maintenance of this material shall be liable for any direct, indirect, special or consequential damages or any other liability arising from any use of this material.
- Revisions to this document may occur after its issuance. The user is responsible for determining if revisions to the material contained in this document have occurred and are applicable.

End of S1000DBIKE-AAA-D00-00-00-00AA-021A-C

End of COPYRIGHT STATEMENTS

INTENTIONALLY BLANK

Administrative and legal statements

S1000DBIKE-AAA-D00-00-00-00AA-023A-C

1. Admin section one

Praeterea, si hujusmodi scientiae plane res mortua non essent, id minime videtur eventurum fuisse quod per multa jam saecula usu venit, ut illae suis immotae fere haereant vestigiis, nec incrementa genere humano digna sumant: eo usque, ut saepenumero non solum assertio maneat assertio sed etiam quaestio maneat quaestio, et per disputationes non solvatur sed figatur et alatur, omnisque traditio et successio disciplinarum repraesentet et exhibeat personas magistri et auditoris, non inventoris et ejus qui inventis aliquid eximium adjiciat. Merito autem temporibus regis omnium sapientissimi et doctissimi Regeneratio ista et Instauratio scientiarum debetur.

2. Important information

Adeo ut Tempus, tanquam fluvius, levia et inflata ad nos devexerit, gravia et solida demerserit.

Atque quae tradita et recepta sunt ad hunc fere modum se habent: quoad opera sterilia, quaestionum plena; incrementis suis tard et languida; perfectionem in tot simulantia, sed per partes male impleta; delectu autem popularia et authoribus ipsis suspecta, ideoque artificiis quibusdam munita et ostentata. Lorem ipsum dolor sit amet, consectetur adipiscing elit, sed diam nonummy nibh euismod tincidunt ut laoreet dolore magna aliquam erat volutpat.

End of S1000DBIKE-AAA-D00-00-00-00AA-023A-C
End of ADMINISTRATIVE AND LEGAL STATEMENTS

INTENTIONALLY BLANK

Safety statements

S1000DBIKE-AAA-D00-00-00-00AA-012A-C

WARNING



Make sure that the bulb is cool before you replace it.

1. Safety

WARNING



Make sure that the bulb is cool before you replace it.

Omnes enim ante nos, qui ad artes inveniendas se applicuerunt, conjectis paulisper in res et exempla et experientiam oculis, statim, quasi inventio nil aliud esset quam quaedam excogitatio, spiritus propios ut sibi oracula exhiberent quodammodo invocarunt. Atque nonnulli rursus qui experientiae undis se commiserere et fere mechanici facti sunt, tamen in ipsa experientia erraticam quandam inquisitionem exercent, nec ei certa lege militant.

End of S1000DBIKE-AAA-D00-00-00-00AA-012A-C

End of SAFETY STATEMENTS

INTENTIONALLY BLANK

List of effective data modules

The LOEDM reflects the status of the data modules used within this publication. The following are the status definitions:

- If the DM is new from the prior release of the publication, an “N” indicates that the data module has been added to the publication since the last release of the publication.
- If the DM is unchanged from the prior release of the publication, the entry is left blank.
- If the DM is changed from the prior release of the publication, a “C” indicates that the data module existed in the previous revision of the publication and has experienced a content change.

Data module title	Data module code	Issue number	Issue date	Status
Brake system - Manual test	BRAKE-AAA-DA1-00-00-00AA-341A-A	002	2016-12-31	N
Bicycle - Library	S1000DBIKE-AAA-D00-00-00-00AA-021A-C	001	2016-12-31	N
Bicycle - Admin and legal	S1000DBIKE-AAA-D00-00-00-00AA-023A-C	001	2016-12-31	N
Bicycle - safety	S1000DBIKE-AAA-D00-00-00-00AA-012A-C	001	2016-12-31	N
Bicycle - change record	S1000DBIKE-AAA-D00-00-00-00AA-003A-C	001	2016-12-31	N
Bicycle - Technical Standard Record	S1000DBIKE-AAA-D00-00-00-00AA-008A-C	001	2016-12-31	N
Bicycle - Introduction	S1000DBIKE-AAA-D00-00-00-00AA-028A-C	001	2016-12-31	N
Bicycle - Nested paras	S1000DBIKE-AAA-D00-00-00-00AA-041D-A	010	2016-12-31	N
Bicycle - Description of how it is made	S1000DBIKE-AAA-D00-00-00-00AA-041A-A	011	2016-12-31	N
Bicycle - Description of function	S1000DBIKE-AAA-D00-00-00-00AA-042A-A	009	2016-12-31	N
Wheel - Description of how it is made	S1000DBIKE-AAA-DA0-00-00-00AA-041A-A	009	2016-12-31	N
Brake system - Description of how it is made	S1000DBIKE-AAA-DA1-00-00-00AA-041A-A	008	2016-12-31	N
Steering - Description of how it is made	S1000DBIKE-AAA-DA2-00-00-00AA-041A-A	009	2016-12-31	N
Headset - Description of how it is made	S1000DBIKE-AAA-DA2-30-00-00AA-041A-A	008	2016-12-31	N
Frame - Description of how it is made	S1000DBIKE-AAA-DA3-00-00-00AA-041A-A	008	2016-12-31	N
Drivetrain - Description of how it is made	S1000DBIKE-AAA-DA4-00-00-00AA-041A-A	008	2016-12-31	N

Data module title	Data module code	Issue number	Issue date	Status
Gears - Description of how it is made	S1000DBIKE-AAA-DA5-00-00-00AA-041A-A	008	2016-12-31	N
Mechs - Description of how it is made	S1000DBIKE-AAA-DA5-10-00-00AA-041A-A	009	2016-12-31	N
Shifters - Description of how it is made	S1000DBIKE-AAA-DA5-30-00-00AA-041A-A	008	2016-12-31	N
Frame - Description of how it is made	S1000DBIKE-AAA-DA3-00-00-00AA-041A-A	008	2016-12-31	N
Drivetrain - Description of how it is made	S1000DBIKE-AAA-DA4-00-00-00AA-041A-A	008	2016-12-31	N
Gears - Description of how it is made	S1000DBIKE-AAA-DA5-00-00-00AA-041A-A	008	2016-12-31	N
Mechs - Description of how it is made	S1000DBIKE-AAA-DA5-10-00-00AA-041A-A	009	2016-12-31	N
Shifters - Description of how it is made	S1000DBIKE-AAA-DA5-30-00-00AA-041A-A	008	2016-12-31	N
Electrical system - Description of how it is made and its function	S1000DLIGHTING-AAA-D00-00-00-00AA-040A-A	008	2016-12-31	N
Fork - Manual test	S1000DBIKE-AAA-D00-00-01-00AA-341A-A	002	2016-12-31	N
Hubs - Test nested steps	S1000DBIKE-AAA-DA5-20-00-00AA-251D-A	009	2016-12-31	N
Chain - Oil	S1000DBIKE-AAA-DA4-10-00-00AA-241A-A	009	2016-12-31	N
Bicycle - Other procedures to clean	S1000DBIKE-AAA-D00-00-00-00AA-258A-A	009	2016-12-31	N
Hubs - Clean with degreasing agent	S1000DBIKE-AAA-DA5-20-00-00AA-251C-A	009	2016-12-31	N
Brake pads - Clean with rubbing alcohol	S1000DBIKE-AAA-DA1-10-00-00AA-251A-A	008	2016-12-31	N
Chain - Clean with chain cleaning fluid	S1000DBIKE-AAA-DA4-10-00-00AA-251B-A	008	2016-12-31	N
internal references - descriptive	S1000DBIKE-AAA-D00-20-00-00AA-041A-A	010	2016-12-31	N
internal references - procedural	S1000DBIKE-AAA-D00-30-00-00AA-041A-A	010	2016-12-31	N
Bicycle - Description of how it is made	S1000DBIKE-AAA-D00-00-00-00AA-02BA-A	010	2016-12-31	N
Bicycle - Other procedures to clean	S1000DBIKE-AAA-D00-00-00-00AA-258B-A	002	2016-12-31	N

Data module title	Data module code	Issue number	Issue date	Status
Inner tube - Remove and install a new item	S1000DBIKE-AAA-DA0-10-10-00AA-921A-A	008	2016-12-31	N
Tire - Check pressure	S1000DBIKE-AAA-DA0-10-20-00AA-362B-A	008	2016-12-31	N
Front wheel - Fault reports and isolation procedures	S1000DBIKE-AAA-DA0-10-20-00AA-400A-A	008	2016-12-31	N
Brake system - Manual test	S1000DBIKE-AAA-DA1-00-00-00AA-341A-A	008	2016-12-31	N
Lights - Manual test	S1000DLIGHTING-AAA-D00-00-00-00AA-341A-A	008	2016-12-31	N
Bicycle - Other procedures to clean	S1000DBIKE-AAA-D00-00-00-01AA-258A-A	009	2016-12-31	N
External Refs - Description of how it is made	S1000DBIKE-AAA-DA5-70-00-00AA-041A-A	008	2016-12-31	N
Fork - Remove procedures	S1000DBIKE-AAA-D00-00-01-00AA-520A-A	002	2016-12-31	N
Rear wheel - Remove procedures	S1000DBIKE-AAA-DA0-20-00-00AA-520A-A	008	2016-12-31	N
Front wheel - Remove procedures	S1000DBIKE-AAA-DA0-30-00-00AA-520A-A	002	2016-12-31	N
Front brake - Remove procedures	S1000DBIKE-AAA-DA1-20-00-00AA-520A-A	002	2016-12-31	N
Stem - Remove procedures	S1000DBIKE-AAA-DA2-10-00-00AA-520A-A	009	2016-12-31	N
Handlebar - Remove procedures	S1000DBIKE-AAA-DA2-20-00-00AA-520A-A	009	2016-12-31	N
Headset - Remove procedures	S1000DBIKE-AAA-DA2-30-00-00AA-520A-A	009	2016-12-31	N
Lighting - Remove and install a new item	S1000DLIGHTING-AAA-D00-00-00-00AA-921A-A	008	2016-12-31	N
Bicycle - Standard repair procedures	S1000DBIKE-AAA-D00-00-00-00AA-663A-A	010	2016-12-31	N
Fork - Replacement procedure	S1000DBIKE-AAA-D00-00-01-00AA-933A-A	002	2016-12-31	N
Tire - Fill with air	S1000DBIKE-AAA-DA0-10-20-00AA-215A-A	008	2016-12-31	N
Fork - Install procedures	S1000DBIKE-AAA-D00-00-01-00AA-720A-A	002	2016-12-31	N
Fork - Install procedures	S1000DBIKE-AAA-D00-00-01-00AB-720A-A	002	2016-12-31	N

Data module title	Data module code	Issue number	Issue date	Status
Fork - Install procedures	S1000DBIKE-AAA-D00-00-01-00AB-720A-A	002	2016-12-31	N
Tire - Remove and install a new item	S1000DBIKE-AAA-DA0-10-20-00AA-921A-A	008	2016-12-31	N
Front wheel - Install procedures	S1000DBIKE-AAA-DA0-30-00-00AA-720A-A	002	2016-12-31	N
Front brake - Install procedures	S1000DBIKE-AAA-DA1-20-00-00AA-720A-A	002	2016-12-31	N
Stem - Install procedures	S1000DBIKE-AAA-DA2-10-00-00AA-720A-A	009	2016-12-31	N
Handlebar - Install procedures	S1000DBIKE-AAA-DA2-20-00-00AA-720A-A	009	2016-12-31	N
Headset - Install procedures	S1000DBIKE-AAA-DA2-30-00-00AA-720A-A	009	2016-12-31	N
Spacer - Install procedures	S1000DBIKE-AAA-DA2-40-00-00AA-720A-A	002	2016-12-31	N
Lighting - Assemble, install and connect procedures	S1000DLIGHTING-AAA-D00-00-00-00AA-700A-A	008	2016-12-31	N
Bicycle - Place on test stand	S1000DBIKE-AAA-D00-00-00-00AA-330A-A	009	2016-12-31	N
Horn - Remove and install a new item	S1000DBIKE-AAA-DA3-10-00-00AA-921A-A	008	2016-12-31	N
Illustrated Parts Data - Introduction	S1000DBIKE-AAA-D00-00-00-00AA-941A-C	001	2016-12-31	N
Bicycle - Illustrated Parts Data - IPD	S1000DBIKE-AAA-D00-00-00-01AA-941A-D	008	2016-12-31	N
Light system - Illustrated Parts Data - IPD	S1000DLIGHTING-AAA-D00-00-00-01AA-941A-D	008	2016-12-31	N
Bicycle - Illustrated Parts Data - IPD TEST	S1000DBIKE-AAA-D00-00-00-02AA-941A-D	008	2016-12-31	N

End of LIST OF EFFECTIVE DATA MODULES

Change record

S1000DBIKE-AAA-D00-00-00-00AA-003A-C

1. Change Record

The change record displays the issue history of the publication.

Issue Number	Issue Date	Issue Number	Issue Date
001	2018-01-03		

*End of S1000DBIKE-AAA-D00-00-00-00AA-003A-C
End of CHANGE RECORD*

INTENTIONALLY BLANK

Highlights

The listed changes are introduced in issue 003, dated 2018-03-01, of this publication.

Publication/Data module	Reason for update	Page number
S1000DBIKE-AAA-D00-00-00-00AA-041A-A	S1000D upissued — CMP testing	FUNC-3
S1000DLIGHTING-AAA-D00-00-00-00AA-040A-A	Derivative Classification	SCHEM-1
S1000DLIGHTING-AAA-D00-00-00-00AA-040A-A	Derivative Classification	SCHEM-1
S1000DBIKE-AAA-DA4-10-00-00AA-241A-A	Main procedure restructured	TS-1
S1000DBIKE-AAA-DA4-10-00-00AA-241A-A	Main procedure restructured	TS-1
S1000DBIKE-AAA-DA4-10-00-00AA-241A-A	Main procedure restructured	TS-2
S1000DBIKE-AAA-D00-00-00-00AA-258A-A	Common Information added	SERVC-2
S1000DBIKE-AAA-D00-00-00-00AA-258A-A	Detergent B substituted by Detergent C	SERVC-1
S1000DBIKE-AAA-D00-00-00-00AA-258A-A	Applicability added/changed	SERVC-3
S1000DBIKE-AAA-D00-00-00-00AA-258A-A	Applicability added/changed	SERVC-3
S1000DBIKE-AAA-D00-00-00-00AA-258A-A	Detergent B substituted by Detergent C	SERVC-7
S1000DBIKE-AAA-D00-00-00-00AA-258A-A	Detergent B substituted by Detergent C	SERVC-7
S1000DBIKE-AAA-D00-00-00-00AA-258A-A	Applicability added/changed	SERVC-7
S1000DBIKE-AAA-D00-00-00-00AA-258A-A	Detergent B substituted by Detergent C	SERVC-7
S1000DBIKE-AAA-D00-00-00-00AA-258B-A	Detergent B substituted by Detergent C	TEST-1
S1000DBIKE-AAA-D00-00-00-01AA-258A-A	Detergent B substituted by Detergent C	TEST-1
S1000DBIKE-AAA-D00-00-00-01AA-258A-A	Applicability added/changed	TEST-10
S1000DBIKE-AAA-D00-00-00-01AA-258A-A	Applicability added/changed	TEST-10

End of HIGHLIGHTS

INTENTIONALLY BLANK

List of abbreviations

Abbreviation	Definition
ATA	AIR TRANSPORT ASSOCIATION OF AMERICA
CMP	Component Maintenance Publication
IPD	Illustrated Parts List

End of LIST OF ABBREVIATIONS

INTENTIONALLY BLANK

List of terms

Term	Definition
cantilever brake	A type of Brake system used on Bicycles
Derailleur	Derailleur gears are a variable-ratio transmission system commonly used on bicycles.
Shifters	Shifters are the mechanism used to move between gears.

End of LIST OF TERMS

INTENTIONALLY BLANK

List of symbols

Symbol	Definition
symbol 1	Warning
symbol 2	Caution

End of LIST OF SYMBOLS

INTENTIONALLY BLANK

Technical standard record

S1000DBIKE-AAA-D00-00-00-00AA-008A-C

1. Technical Standard Record

The TSR lists service bulletins incorporated into this publication.

SB Number	SB Title	SB Revision Number	SB Date	CMP Issue Number
222-333-44	New-fangled widget	001	2018-01-01	001

*End of S1000DBIKE-AAA-D00-00-00-00AA-008A-C
End of TECHNICAL STANDARD RECORD*

INTENTIONALLY BLANK

Table of contents

Section	Page
Front Matter and Introduction	
Title page.....	TP-1
Configuration.....	CONF-1
Brake Test.....	CONF-1
Copyright statements.....	COPY-1
Copyright.....	COPY-1
Administrative and legal statements.....	ADMIN-1
Admin section one.....	ADMIN-1
Important information.....	ADMIN-1
Safety statements.....	SAFE-1
Safety.....	SAFE-1
List of effective data modules.....	LOEDM-1
Change record.....	CR-1
Change Record.....	CR-1
Highlights.....	HIGH-1
List of abbreviations.....	LOA-1
List of terms.....	LOT-1
List of symbols.....	LOS-1
Technical standard record.....	TSR-1
Technical Standard Record.....	TSR-1
Table of contents.....	TOC-1
List of illustrations.....	LOI-1
List of tables.....	LOTBL-1
List of applicable specifications and documentation.....	LOASD-1
List of suppliers.....	LOSUP-1
List of support equipment.....	LOSE-1
List of supplies.....	LOSU-1
List of spares.....	LOSP-1
Introduction.....	INTRO-1
Introduction.....	INTRO-1
Functional and technical description	
Description of function.....	FUNC-1
Level 1 Title 1.....	FUNC-1
Physical description of a bicycle.....	FUNC-1

Section	Page
Extra content.....	FUNC-3
Functional description of a bicycle.....	FUNC-3
The bicycle wheel.....	FUNC-5
Brake system.....	FUNC-7
Steering.....	FUNC-14
Headset.....	FUNC-14
The bicycle frame.....	FUNC-17
Drive train.....	FUNC-20
Gears.....	FUNC-20
Derailleur.....	FUNC-20
Shifters.....	FUNC-24
How a thumb shifter is made up.....	FUNC-26
Technical description.....	DESC-1
The bicycle frame.....	DESC-1
Drive train.....	DESC-4
Gears.....	DESC-4
Derailleur.....	DESC-4
Shifters.....	DESC-8
How a thumb shifter is made up.....	DESC-10
Diagrams and schematics.....	SCHEM-1
Lighting system.....	SCHEM-1
Maintenance and servicing	
Task sets.....	TS-1
Fork testing.....	TS-1
level 1 Title 1.....	TS-2
Apply the penetrating lubricant into all the parts of the bike that move.....	TS-2
Lubricate the chain.....	TS-7
Check lubricated parts.....	TS-9
Servicing.....	SERV-1
Common Information.....	SERV-2
Cleaning the Bicycle.....	SERV-3
Hub Cleaning.....	SERV-7
Brake pad cleaning.....	SERV-10
Chain cleaning.....	SERV-10
Internal References.....	SERV-12

Section	Page
Examination, test, checks, and fault isolation.....	TEST-1
Common Information.....	TEST-1
Cleaning the bike.....	TEST-2
Inner tube installation.....	TEST-7
Check Tire Pressure.....	TEST-9
Front wheel fault isolation.....	TEST-9
Brake testing.....	TEST-10
Lights testing.....	TEST-10
referring to the Bicycle.....	TEST-11
external refs.....	TEST-14
Disassemble.....	DIS-1
Removing the fork.....	DIS-1
Rear wheel removal.....	DIS-2
Front wheel removal.....	DIS-2
Front brake removal.....	DIS-2
Stem removal.....	DIS-2
Remove the grips.....	DIS-4
Remove the brake and the shift levers from the handlebars.....	DIS-4
Remove the handlebar.....	DIS-6
Headset removal.....	DIS-8
Lighting replacement.....	DIS-10
Repair.....	REP-1
Repair procedures.....	REP-1
PREPARATION.....	REP-12
PROCEDURE.....	REP-12
TEST.....	REP-12
Inflating the tire.....	REP-12
Assemble.....	ASSY-1
Fork Installation.....	ASSY-2
Fork installation.....	ASSY-2
Fork installation.....	ASSY-2
Tire replacement.....	ASSY-2
Front wheel installation.....	ASSY-3
Front brake installation.....	ASSY-3
Stem installation.....	ASSY-4

Section	Page
Handelbar installation.....	ASSY-8
Headset installation.....	ASSY-9
Spacer installtion.....	ASSY-9
Lighting assembly.....	ASSY-9
Storage.....	STORE-1
Test Stand.....	STORE-1
Horn replacement.....	STORE-1
Illustrated Parts Data	
Illustrated parts data.....	IPD-1
Introduction.....	IPD-1
Explanation and Usage of Section.....	IPD-1
Numerical index.....	IPD-5
Equipment designator index.....	IPD-9
Illustrated parts data.....	IPD-11
Bicycle.....	IPD-12
Light system.....	IPD-15
Bicycle test bits.....	IPD-18

End of TABLE OF CONTENTS

List of illustrations

Figure	Title	Page
Fig FUNC-1	Complete bicycle.....	FUNC-2
Fig FUNC-2	Parts of the wheel.....	FUNC-5
Fig FUNC-3	The tire and rim.....	FUNC-6
Fig FUNC-4	Valve.....	FUNC-7
Fig FUNC-5	Cantilever brake with straddle cable.....	FUNC-9
Fig FUNC-6	Exploded diagram of a brake.....	FUNC-11
Fig FUNC-7	Typical components of a mountain bicycle lever.....	FUNC-13
Fig FUNC-8	Headset.....	FUNC-16
Fig FUNC-9	Welded frame joints.....	FUNC-18
Fig FUNC-10	Frame.....	FUNC-19
Fig FUNC-11	Front derailleur.....	FUNC-21
Fig FUNC-12	Rear derailleur.....	FUNC-23
Fig FUNC-13	Thumb shifter index type.....	FUNC-25
Fig FUNC-14	Unscrew wingnut.....	FUNC-27
Fig FUNC-15	Loosen the nut.....	FUNC-28
Fig FUNC-16	Loosen the shifter clamp bolt.....	FUNC-30
Fig DESC-1	Welded frame joints.....	DESC-2
Fig DESC-2	Frame.....	DESC-3
Fig DESC-3	Front derailleur.....	DESC-5
Fig DESC-4	Rear derailleur.....	DESC-7
Fig DESC-5	Thumb shifter index type.....	DESC-9
Fig DESC-6	Unscrew wingnut.....	DESC-11
Fig DESC-7	Loosen the nut.....	DESC-12
Fig DESC-8	Loosen the shifter clamp bolt.....	DESC-14
Fig SCHEM-1	Lighting system.....	SCHEM-1
Fig TS-1	Derailleur pivots.....	TS-3
Fig TS-2	Derailleur tension.....	TS-4
Fig TS-3	Brake lever pivots.....	TS-6
Fig TS-4	Lubricate the chain.....	TS-8
Fig SERVC-1	Cleaning the bike.....	SERVC-4
Fig SERVC-2	Degreasing the freehub.....	SERVC-6
Fig SERVC-3	Removing the axle.....	SERVC-9
Fig SERVC-4	sample graphic.....	SERVC-12
Fig TEST-1	Cleaning the bike.....	TEST-3

Figure	Title	Page
Fig TEST-2	Degreasing the freehub.....	TEST-5
Fig TEST-3	Removing the inner tube.....	TEST-8
Fig TEST-4	Cleaning the bike.....	TEST-12
Fig DIS-1	Remove the bolt.....	DIS-3
Fig DIS-2	Loosen the clamp screw with the Allen wrench.....	DIS-5
Fig DIS-3	Loosen the clamp bolt.....	DIS-7
Fig DIS-4	Lift the upper bearing cup.....	DIS-9
Fig REP-1	Unseating the tire with a tire lever.....	REP-3
Fig REP-2	Circle leak.....	REP-5
Fig REP-3	Sanding the application area.....	REP-7
Fig REP-4	Apply glue to application area.....	REP-9
Fig REP-5	Apply pressure to tube.....	REP-11
Fig ASSY-1	Lubricate the thread.....	ASSY-5
Fig ASSY-2	Tighten the bolt.....	ASSY-7
IPD Figure D00-00-00-01A	Bicycle.....	IPD-12
IPD Figure D00-00-00-01	Light system.....	IPD-15
IPD Figure D00-00-00-01A	Bicycle test bits.....	IPD-18

End of LIST OF ILLUSTRATIONS

List of tables

Table	Title	Page
Table CONF-1	Support equipment.....	CONF-1
Table CONF-2	Consumables, materials and expendables.....	CONF-1
Table CONF-3	Spares.....	CONF-1
Table FUNC-1	Bicycle parts.....	FUNC-2
Table TS-1	Support equipment.....	TS-1
Table TS-2	Consumables, materials and expendables.....	TS-1
Table TS-3	Spares.....	TS-1
Table TS-4	Required conditions.....	TS-1
Table TS-5	Required conditions.....	TS-2
Table SERVC-1	Support equipment.....	SERV-1
Table SERVC-2	Consumables, materials and expendables.....	SERV-1
Table SERVC-3	Spares.....	SERV-2
Table SERVC-4	Required conditions.....	SERV-2
Table SERVC-5	Required conditions.....	SERV-7
Table SERVC-6	Required conditions.....	SERV-7
Table SERVC-7	Required conditions.....	SERV-11
Table SERVC-8	sample table.....	SERV-12
Table TEST-1	Support equipment.....	TEST-1
Table TEST-2	Consumables, materials and expendables.....	TEST-1
Table TEST-3	Spares.....	TEST-1
Table TEST-4	Required conditions.....	TEST-2
Table TEST-5	Required conditions.....	TEST-6
Table TEST-6	Required conditions.....	TEST-6
Table TEST-7	Required conditions.....	TEST-9
Table TEST-8	Required conditions.....	TEST-10
Table TEST-9	Dummy table.....	TEST-14
Table TEST-10	Required conditions.....	TEST-14
Table DIS-1	Support equipment.....	DIS-1
Table DIS-2	Consumables, materials and expendables.....	DIS-1
Table DIS-3	Spares.....	DIS-1
Table DIS-4	Required conditions.....	DIS-2
Table DIS-5	Required conditions.....	DIS-4
Table DIS-6	Required conditions.....	DIS-8
Table DIS-7	Required conditions.....	DIS-10

Table	Title	Page
Table DIS-8	Required conditions.....	DIS-11
Table REP-1	Support equipment.....	REP-1
Table REP-2	Consumables, materials and expendables.....	REP-1
Table REP-3	Spares.....	REP-1
Table ASSY-1	Support equipment.....	ASSY-1
Table ASSY-2	Consumables, materials and expendables.....	ASSY-1
Table ASSY-3	Spares.....	ASSY-1
Table ASSY-4	Required conditions.....	ASSY-3
Table ASSY-5	Required conditions.....	ASSY-4
Table ASSY-6	Required conditions.....	ASSY-8
Table ASSY-7	Required conditions.....	ASSY-9
Table ASSY-8	Required conditions.....	ASSY-9
Table STORE-1	Support equipment.....	STORE-1
Table STORE-2	Consumables, materials and expendables.....	STORE-1
Table STORE-3	Spares.....	STORE-1
Table STORE-4	Required conditions.....	STORE-2
Table IPD-1	Interchangeability Definitions.....	IPD-2

End of LIST OF TABLES

List of applicable specifications and documentation

Data module/Technical publication	Title
S1000DBIKE-B6865-SAFE1-00	
SafeS-12-156B	Sticky stuff - Safety sheet, 2014
CMM code1234	title, ddfdfd
BRAKE-B6865-EPWG1-00	Brakes , Issue 2016-12-31, (BRAKE), (CAGE B6865)
ATA CMM 23-10-11	Power Supply, Revision 003 Local Disposal Procedures

End of LIST OF APPLICABLE SPECIFICATIONS AND DOCUMENTATION

INTENTIONALLY BLANK

List of suppliers

MFR	Supplier
AMB	
AN777	A N Other Ltd, 21 Acacia Avenue, London, SW1, UK
B6865	AEROSPACE AND DEFENCE INDUSTRIES ASSOCIATION OF EUROPE, 10 Somewhere else, New York, QQ1234, USA
Bikey	
HS111	
K2777	
KD559	
KK999	
KT222	
KT444	
KT666	
KZ222	
KZ444	
KZ555	
KZ666	Widgets Ltd, 10 Nopaddle Creek, London, SW1, UK
KZ777	
KZ888	
KZ999	
M1234	MEKON Ltd, 31–35 St Nicholas Way, Sutton, Surrey, SM1 1JN, UK
Stand	
ZZ	
ZZZ	

End of LIST OF SUPPLIERS

INTENTIONALLY BLANK

List of support equipment

Equivalent substitutes may be used, unless otherwise specified.

Refer to the "List of suppliers" for MFR information.

Name	Identification/Reference	MFR
Chain cleaning fluid	LL-003	KZ222
Chain cleaning tool	BSK-TLST-001-03	KZ666
Clean dry cloth	BSK-TLST-001-12	KZ666
even shaped thingy	XYZ789-A	M1234
Extra firm hold hairspray	HSP-D001	HS111
Floor covering	PPP-001	KK999
Foot pump	BSK-TLST-001-05	KZ666
Marker pen	BSK-TLST-001-07	KZ666
odd shaped thingy	XYZ789	M1234
Saw tool set		M1234
- Saw tool set	BSK-STS-001	
Set of Allen wrenches	BSK-TLST-001-13	KZ666
Special Toolset		
- Screwdriver	BSK-SCRDV-001	
Specialist toolset	BSK-TLST-001	KZ666
Sponge	BSK-TLST-001-11	KZ666
Stiff bristle brush	BSK-TLST-001-02	KZ666
Test stand	BSK-TLST-999-01	KZ666
Tire lever	BSK-TLST-001-04	KZ666
Tire pressure gauge	BSK-TLST-001-01	
Tire pressure gauge	BSK-TLST-001-01	KZ666
Tire pressure gauge xx	BSK-TLST-001-01	KZ666
Tire pressure guage	BSK-TLST-001-01	KZ666
Torque wrench 1	1234	ZZZ
Torque wrench 2	BSK-TLST-001-01	KZ666
Tube patch kit	BSK-TLST-001-07	KZ666
useful widget	BSK-STS-001	
Water hose	BSK-TLST-001-09	KZ666
- embed	123	ZZ
Water hose	BSK-TLST-001-09	KZ666
Work stand	Stand-001	KZ555
Work stand	Stand-001	Bikey

COMPONENT MAINTENANCE PUBLICATION

S1000DBIKE-KD559-CMPXX-00

TEST

Name	Identification/Reference	MFR
Work stand	Stand-001	Stand
8mm Allen wrench	BSK-TLST-001-08	KZ666

End of LIST OF SUPPORT EQUIPMENT

List of supplies

Equivalent substitutes may be used, unless otherwise specified.

Refer to the "List of suppliers" for MFR information.

Name	Identification/Reference	MFR
	BSB-DUROFIX_FIXATIF_UW	
	BSB-DUROFIX_FIXATIF_UW_SPECIAL	
ACME Middling Detergent 69	BSK-TLST-023-14	KZ666
ACME sticky lube 52B	LL-007	KZ222
ACME super 45 Agent	LL-004	AN777
- embedded Supplies	1234	AMB
AECMA Heavy duty Oil 1988	HD1988	B6865
BoeBus DeLux Detergent No.6	BSK-TLST-001-15	KZ666
Degreasing agent	LL-004	KZ222
Floor covering	PPP-001	KK999
General grease	LL-005	KZ222
General lubricant	LL-001	KZ222
glue	BSB-DUROFIX_FIXATIF_UW	
Lubricating grease 1	1234	ZZZ
Lubricating grease 2	GRL-1234	
magnetic tape	MB512	M1234
polytetraflouroethylene tape	Q2228	M1234
Rubbing alcohol	LL-002	KZ222
Thingy	Q12343	M1234
whatsit	Q56567	M1234

End of LIST OF SUPPLIES

INTENTIONALLY BLANK

List of spares

Refer to the "List of suppliers" for MFR information.

Name	Identification/Reference	MFR
Brake cable hangar	BR-LVRS-002	KT444
Brake lever	BR-LVRS-001	KT444
Brake lever mount	BR-LVRS-001-01	KT444
Bulb	LIRUS-L1-11	KZ777
	CSN D00-00-00 Fig 01A Item 010A	
Conical expansion washer	St-001-05	KZ555
Dust seal	St-001-04	KZ555
fancy liner thingy	G5537	M1234
Fork	Q7777	M1234
	CSN D00-00-00 Fig 01 Item 006	
- Fork	FK-TEL1002	KZ666
Fork	FK-TEL1002	KZ666
- Fork	FK-TEL1002	KZ666
Fork set	Q1213	M1234
- Fork set		KZ666
Fork set	SPA-1000-1	KZ666
- Fork	FK-TEL1001	KZ666
Frame fork	St-001-02	KZ555
Gasket 1	1234	ZZZ
Gasket 2		
Gasket 3	1234	ZZZ
	CSN 23-10-10 Fig 03A Item 020A	
Glass	LIRUS-G1-10	KZ777
	CSN D00-00-00 Fig 01A Item 022A	
Glass	LIRUS-G1-10H	KZ777
	CSN D00-00-00 Fig 01A Item 023A	
- Glass	LIRUS-G1-10	KZ777
	CSN D00-00-00 Fig 01A Item 022A	
Handlebar	Hd-001	KZ555
Handlebar grips	Hd-001-01	KZ555
Handlebar plug	Hd-001-02	KZ555
Horn	Horn-001	KZ444
Inner tube	IT-001	KT222
Inner-tube	IT-001	KT222
Kit		KZ777

Name	Identification/Reference	MFR
- Bulb ¹	LIRUS-B1-12F CSN D00-00-00 Fig 01A Item 020A	KZ777
- Bulb ¹	LIRUS-B1-12R CSN D00-00-00 Fig 01A Item 021A	KZ777
light part	LRU1012 CSN Fig 01A Item 003A	K2777
Light system		
Shifter lever	SI-001	KZ555
spare 1	123	AMB
spare 2	123	AMB
- embedded spare	123	AMB
spare 3	123	AMB
Stem	St-001	KZ555
Stem bolt	St-001-01	KZ555
thermal sealent	YT6589	M1234
Tire	TIRES-010101	KT666
Upper bearing cup	St-001-03	KZ555

Note 1: Make sure that the new bulb is not cracked.

End of LIST OF SPARES

Introduction

S1000DBIKE-AAA-D00-00-00-00AA-028A-C

1. Introduction

Atque nonnulli rursus qui experientiae undis se commiserere et fere mechanici facti sunt, tamen in ipsa experientia erraticam quandam inquisitionem exercent, nec ei certa lege militant. Illud enim in eo solummodo mirabile est, initia rei et tantas de iis quae invaluerunt suspiciones alicui in mentem venire potuisse. The TSR lists service bulletins incorporated into this publication.

Lorem ipsum dolor sit amet, consectetur adipiscing elit, sed diam nonummy nibh euismod tincidunt ut laoreet dolore magna aliquam erat volutpat. Ita fit, ut aut artes receptas insanis pretiis aestimantes nil amplius quaerant, aut seipsos plus aequo contemnentis vires suas in levioribus consumant, in iis quae ad summum rei faciant non experiantur.

End of S1000DBIKE-AAA-D00-00-00-00AA-028A-C

End of INTRODUCTION

End of FRONT MATTER AND INTRODUCTION

INTENTIONALLY BLANK

Functional and technical description

Description of function

S1000DBIKE-AAA-D00-00-00-00AA-041D-A

1. Level 1 Title 1.

A. Level 2 Title A.

CDDL0 Level 2 Para B.

CDDL0 Level 2 Para B.

CDDL0 Level 2 Para B.

CDDL0 Level 2 Para B.

B. Level 2 Title A.

CDDL0 Level 2 Para B.

CDDL0 Level 2 Para B.

CDDL0 Level 2 Para B.

CDDL0 Level 2 Para B.

C. CDDL1 CDDL0 Level 2 Para B.

(1) CDDL1 CDDL0 Level 3 Para (1.)

(a) CDDL1 CDDL0 Level 4 Para (a)

1. CDDL1 CDDL0 Level 5 Para 1.

End of S1000DBIKE-AAA-D00-00-00-00AA-041D-A

S1000DBIKE-AAA-D00-00-00-00AA-041A-A

2. Physical description of a bicycle

A bicycle (refer to [Fig FUNC-1](#)) is a frame and a number of movable components with mechanical parts that are completely open. There are no covers or sheet metal panels that prevent access to the mechanical parts. Thus, you can disassemble the different components of a bicycle (refer to [Fig FUNC-1 \[0\]](#)) to do:

- an inspection
- a maintenance task
- a repair task

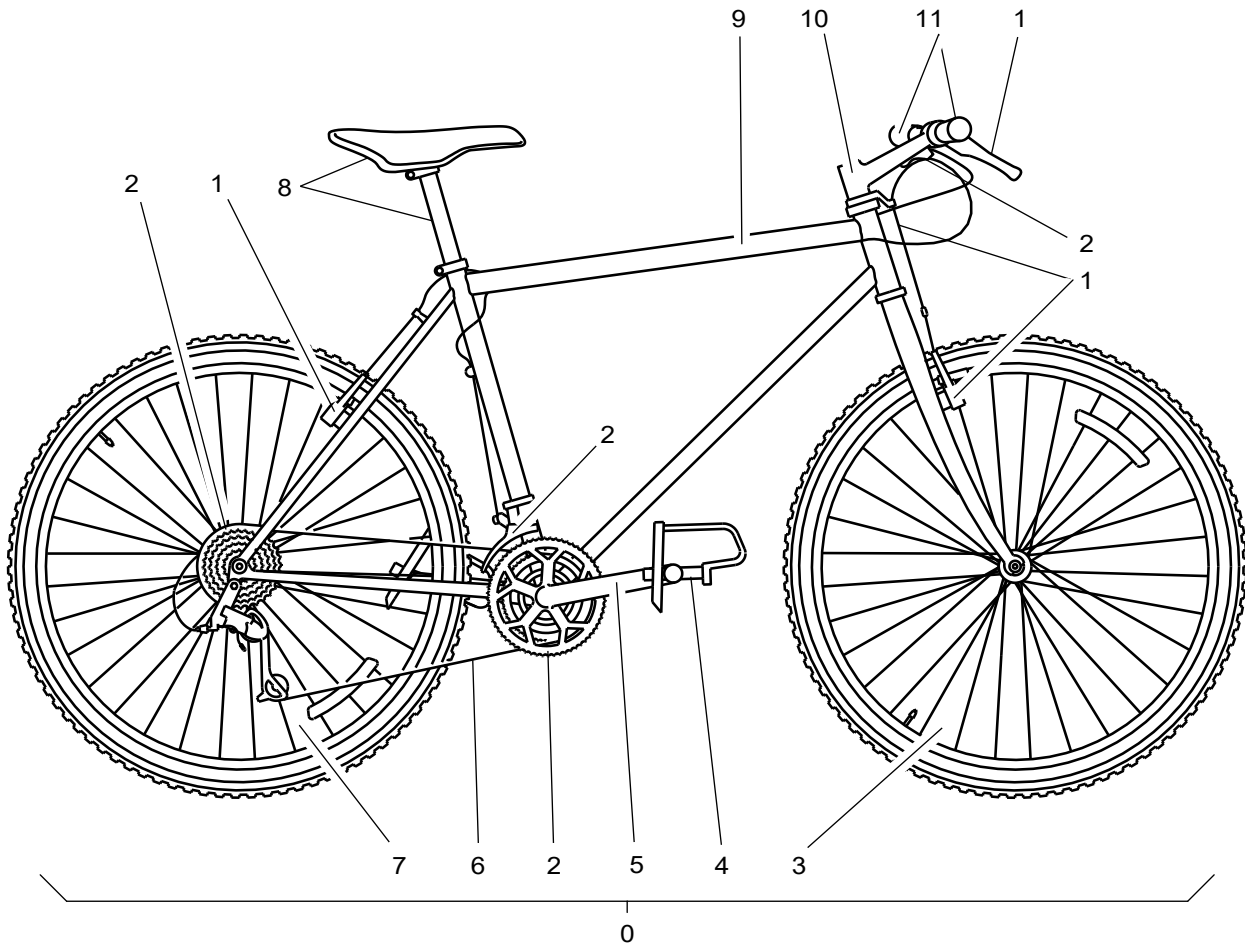

ICN-C0419-S1000D0360-001-01

Figure FUNC-1 Complete bicycle

The parts that you can immediately identify on a bicycle are given in [Table FUNC-1](#).

Table FUNC-1 Bicycle parts

Item	Refer to	Definition
Frame	Fig FUNC-1 [9]	A bicycle frame is made of metal tubes that are welded together.
Wheels		The wheels include these parts: <ul style="list-style-type: none"> - Hub - Spokes - Metal rim - Rubber tire
- Rear wheel	Fig FUNC-1 [7]	

Table FUNC-1 Bicycle parts (Continued)

Item	Refer to	Definition
- Front wheel	Fig FUNC-1 [3]	
Seat and seat post	Fig FUNC-1 [8]	These install into the seat tube with a mechanism you can use to change the height.
Handle bars	Fig FUNC-1 [11]	A horizontal bar that attaches to the stem with grips at the ends that attach to the brake levers and the shifters.
Handle bar stem	Fig FUNC-1 [10]	This attaches the handle bar to the steering tube (head set).
Cranks	Fig FUNC-1 [5]	A lever that extends from the bottom of the bracket to the pedal.
Pedals	Fig FUNC-1 [4]	The two platforms for the feet that attach to the crank.
Chain	Fig FUNC-1 [6]	A circular set of links that connect the chain ring to the cogs on the freewheel.
Gears	Fig FUNC-1 [2]	The gears include: <ul style="list-style-type: none"> - Front chain ring - Rear freewheel - Front and the rear derailleur - Shift lever on the handle bars - Cables
Brakes	Fig FUNC-1 [1]	The brakes include: <ul style="list-style-type: none"> - Actuators on the handlebars - Brake cable - Brake callipers - Brake pads

3. Extra content

Rectius illud et verius, istas scientiarum mancipationes nil aliud esse quam rem ex paucorum hominum confidentia et reliquorum socordia et inertia natam.

End of S1000DBIKE-AAA-D00-00-00-00AA-041A-A

S1000DBIKE-AAA-D00-00-00-00AA-042A-A

4. Functional description of a bicycle

Below is a list of the different bicycle components and a functional description of them.

Frame The frame is the skeleton of the bicycle. Refer to [S1000DBIKE-AAA-DA3-00-00-00AA-041A-A](#) for a functional description of the frame system.

Wheel The wheel is the point of contact between the bicycle and the road for the bicycle to have movement. Refer to [S1000DBIKE-AAA-DA0-00-00-00AA-041A-A](#) for a functional description of the wheel.

Spokes	The spokes are thick wires with tension applied that connect the hub to the rim. You can adjust the tension with the nipple on the rim side.
Hub	The hub attaches to the center of the wheel where the axle and the bearings are.
Metal rim	The metal rim is a metal ring that has a U-shaped cross section to hold the spokes on the inner side and the tire on the outer side.
Seat	The seat, which is also known as the "saddle", is used as the support platform for the person to sit on the bicycle.
Seat post	The seat post is used as a support post for the seat and to change the height of the seat for the rider.
Handle bar	The handle bar is a horizontal bar with handles on each end. The handle bar is a steering mechanism that the rider uses to change the direction of the bicycle. The brake levers are also on the handle bar. Refer to S1000DBIKE-AAA-DA2-20-00-00AA-720A-A for information on how to install the handle bar. Refer to S1000DBIKE-AAA-DA2-20-00-00AA-520A-A for information on removing the handlebar.
Handle bar stem	The handle bar stem (the stem) attaches the handle bar to the steering tube. Refer to S1000DBIKE-AAA-DA2-10-00-00AA-720A-A for information on how to install a stem. Refer to S1000DBIKE-AAA-DA2-10-00-00AA-520A-A for information on how to remove the stem.
Brake levers	When you operate the brake lever, the brake pads move against the wheel to decrease the speed. The brake lever on the left side operates the front brake. The brake lever on the right side operates the rear brake.
Brakes	When you operate the brakes, the brake pad moves against the wheel to decrease the speed of the bicycle. Refer to S1000DBIKE-AAA-DA1-00-00-00AA-041A-A for a description of the braking system.
Shifters	The shifters are the mechanisms that you use to change the gears on the bicycle. There are 7 different types of shifters that have been developed over the years, but they all have the same functionality. When you operate the shifters, they pull the control cable to move the derailleur towards a larger diameter chain ring. The shifters can also loosen the cable to let the derailleur move towards a smaller diameter chain ring. Refer to S1000DBIKE-AAA-DA5-30-00-00AA-041A-A for a functional description of the shifters.
Crank	The crank moves the power to the chain rings when the pedals operate.
Pedals	The pedals move the force of movement from the feet to the cranks.
Chain	The chain moves the power from the chain rings to the cogs on the freewheel. Refer to S1000DBIKE-AAA-DA4-10-00-00AA-251B-A for the procedure on how to clean the chain.
Gears	<p>The gears have different mechanisms that function together to change the speed of the bicycle. These mechanisms include:</p> <ul style="list-style-type: none"> - the sprockets - the chain - the derailleur <p>Refer to S1000DBIKE-AAA-DA5-00-00-00AA-041A-A for a functional description of the gear system.</p>
Chain rings	The chain rings (also known as the "chain wheel") pull on the chain when the cranks turn.

Derailleur A derailleur moves the chain from one sprocket to another to change the gears. There are two different types of derailleur, the front and the rear. The highest ratio (highest gear) is when the chain is on the largest sprocket on the front and the smallest at the rear. To get the lowest gear, the smallest sprocket is at the front and the largest at the rear. Refer to [S1000DBIKE-AAA-DA5-10-00-00AA-041A-A](#) for a functional description of the derailleur system.

End of S1000DBIKE-AAA-D00-00-00-00AA-042A-A

S1000DBIKE-AAA-DA0-00-00-00AA-041A-A

5. The bicycle wheel

The wheel (refer to [Fig FUNC-2](#)) of a bicycle is a complex structure. The wheel assembly has these parts:

- the tire
- the tube
- the spokes
- the spoke nipples
- the valve
- the hub

On their own, the individual components are not very strong. But, when they are installed together, the components make the complete wheel (refer to [Fig FUNC-2](#)). The complete wheel is resistant to almost any type of heavy loads and operation.

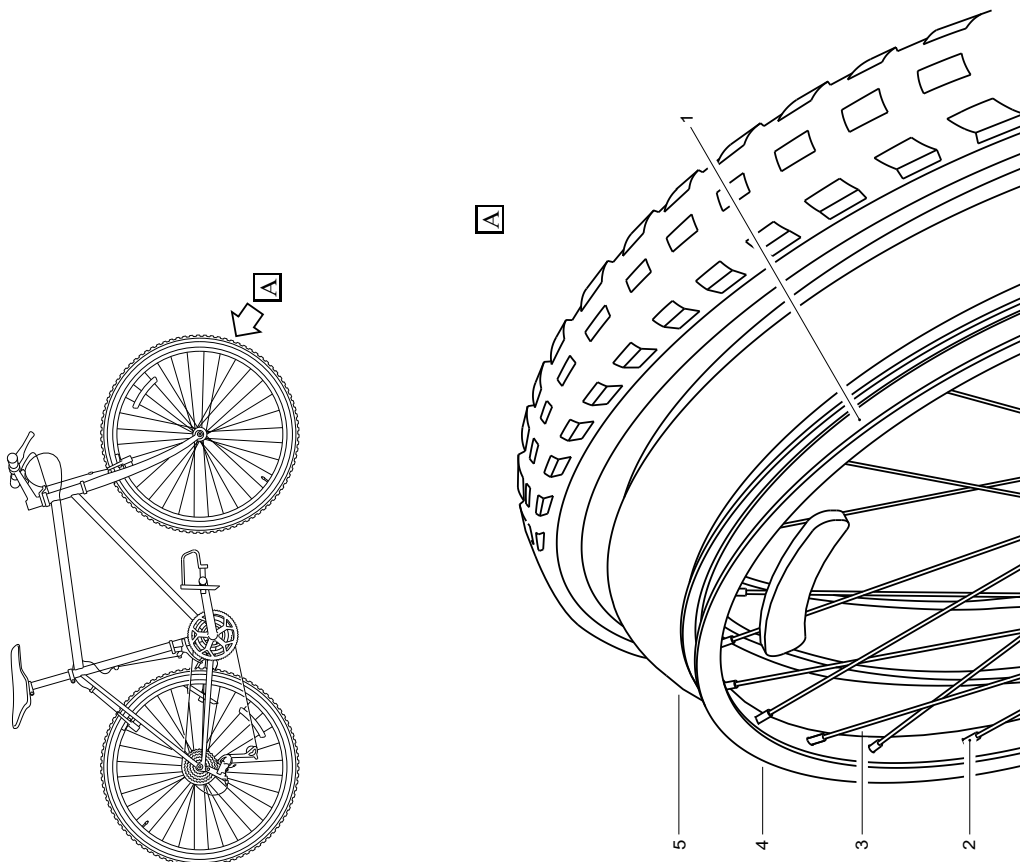

ICN-C0419-S1000D0365-001-01

Figure FUNC-2 Parts of the wheel

A. Spokes

The spokes go out from the hub and go across and below each other. The spoke nipples attach the spokes to the rim with the threads on the end of the spokes. You can use the spoke nipples to adjust the tension of the spokes. The tension on each of the spokes must be equal.

B. Wheel rim

The rim (refer to [Fig FUNC-3](#)) of the wheel has a lining of rim tape. This tape protects the tube from damage that the rough edges on the spoke nipples can cause.

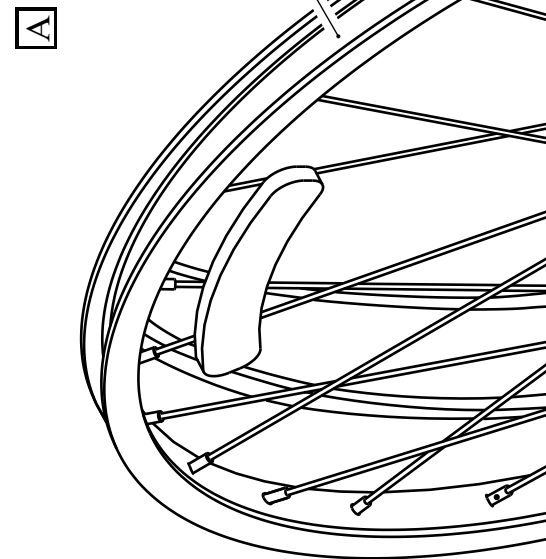
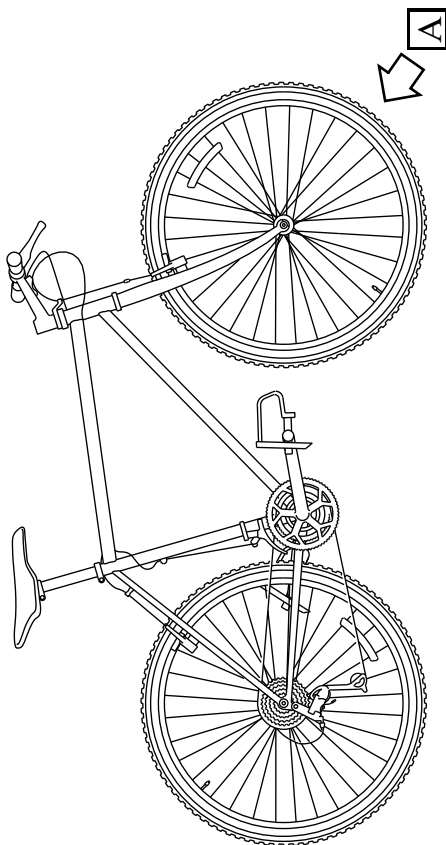

C. Tube and tire

The tube and the tire install on the rim. The sidewalls of the tire have markings on them. These which are used to indicate the correct direction of rotation. The markings also make sure the tire

installs on the rim and that the directional arrows points in the correct direction. You install the tube into the tire before you inflate it. The tube has a valve (refer to [Fig FUNC-4](#)) which you put through the hole in the rim. This valve (refer to [Fig FUNC-4](#)) is used to inflate the tube and the tire to the correct pressure. A dust cap installs on the valve (refer to [Fig FUNC-4](#)) to prevent damage that dust and debris can cause.

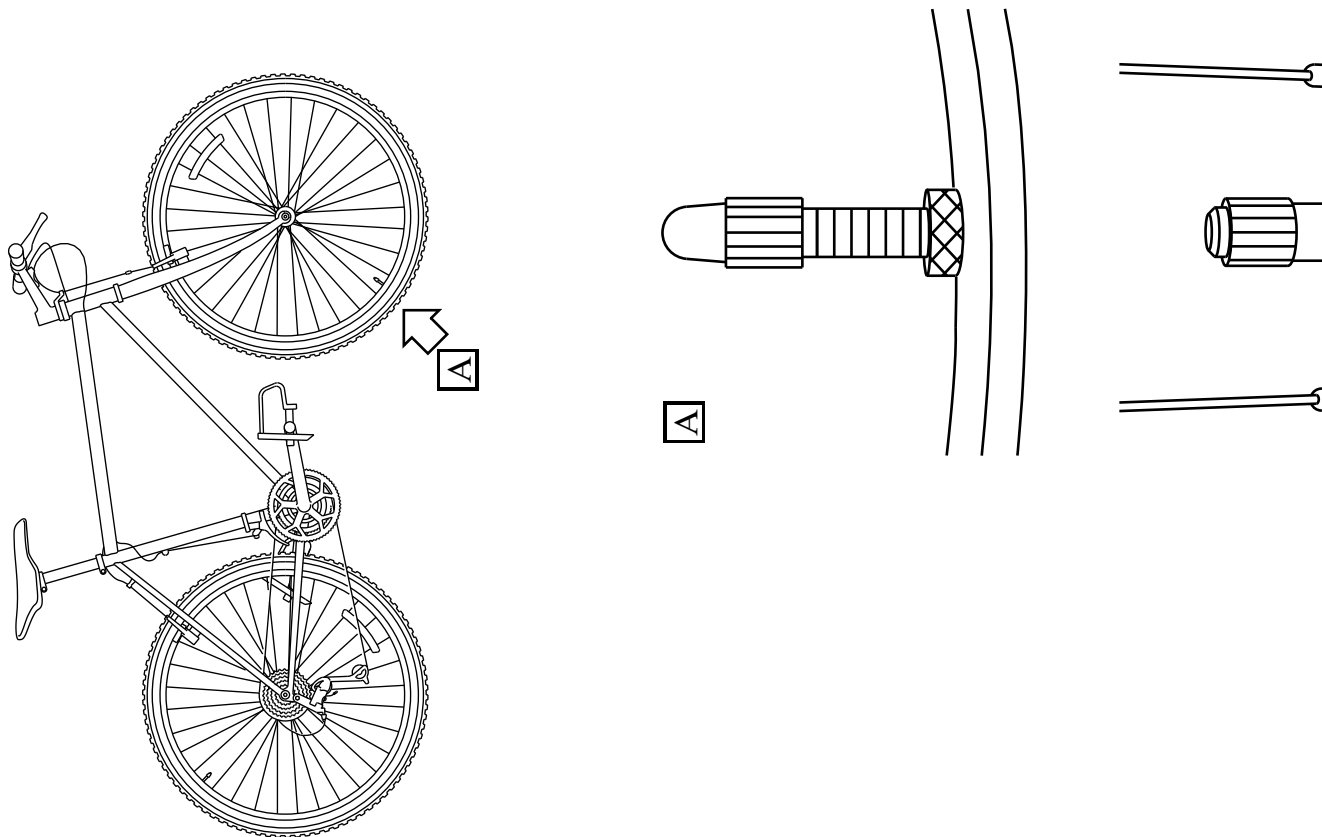

End of S1000DBIKE-AAA-DA0-00-00-00AA-041A-A

S1000DBIKE-AAA-DA1-00-00-00AA-041A-A

6. Brake system

The most important part of the bicycle is the brake system. Only a minimum maintenance of the brake system is necessary. But, when a problem does occur, make sure you do the necessary maintenance as quickly as possible. If you do not do this the bicycle will be dangerous to use.

There are nine different types of brake systems. The one found on most bicycles is the cantilever brake (refer to [Para 6.A.](#)). A type of Brake system used on Bicycles (cantilever brake)

A. Cantilever brake

The brake system (refer to [Fig FUNC-5](#)) has these primary components:

- the brake lever (refer to [Para 6.C.](#))
- the brake cable
- the brake arm
- the brake clamp (also known as callipers)
- the brake pads (refer to [Para 6.B.](#))

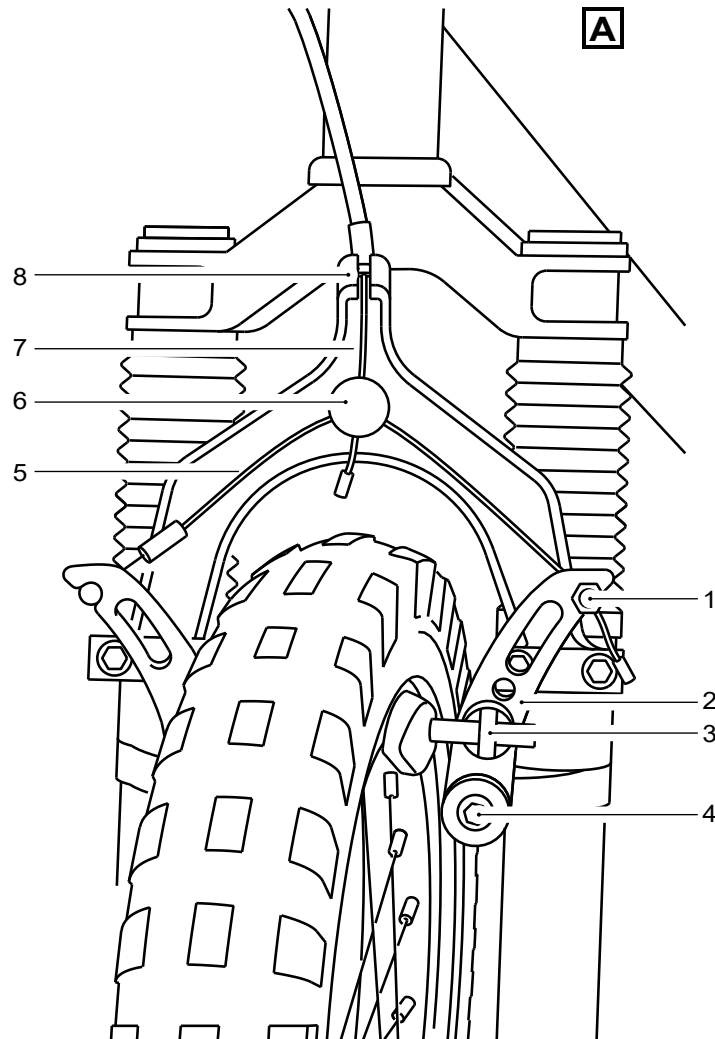
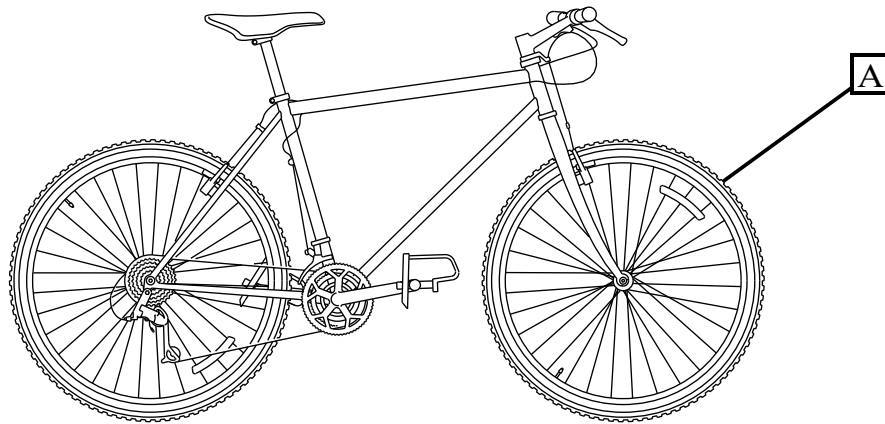

ICN-C0419-S1000D0379-001-01

Figure FUNC-5 Cantilever brake with straddle cable

DESCRIPTION OF FUNCTION

2018-03-01

Page FUNC-9

CTM23-10-10

Copyright (C) 2025 by Contiem Ltd

A cable that goes from the brake levers on the handlebars pulls the two levers on the brakes together. This presses the brake pads against the outer rim of the wheel, which decreases the speed of the bicycle.

B. Brake pads

There are four brake pads (refer to [Fig FUNC-6](#)) on the bicycle. Two are found on the front wheel and two on the rear wheel. The brake pads are made out of hard wearing rubber. The pads press against the rim of the wheel to cause friction when the you operate the brake levers.

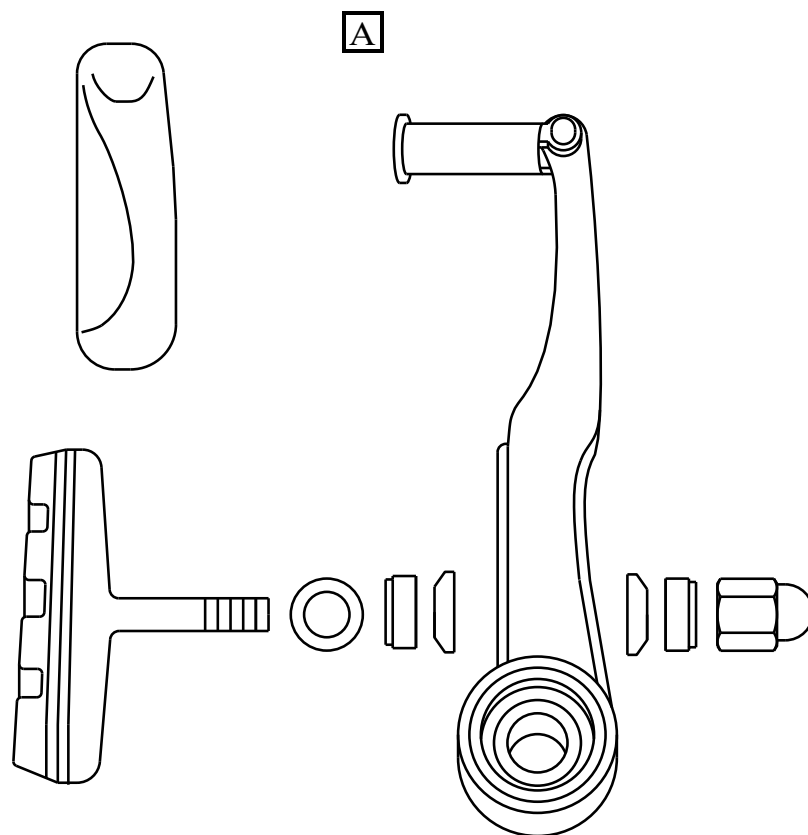
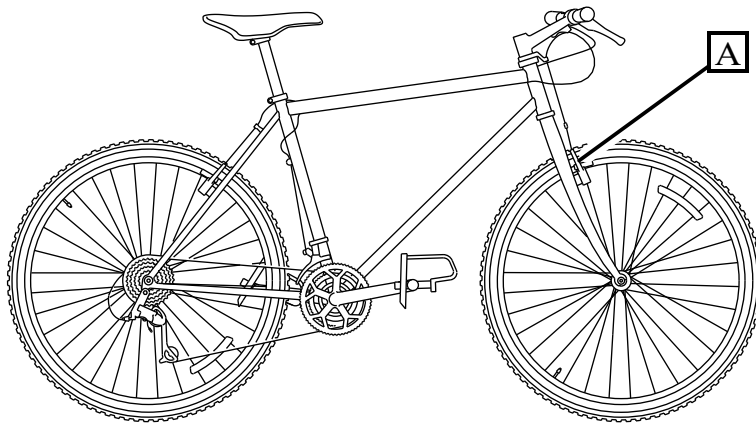

ICN-C0419-S1000D0380-001-01

Figure FUNC-6 Exploded diagram of a brake

DESCRIPTION OF FUNCTION

2018-03-01

Page FUNC-11

CTM23-10-10

Copyright (C) 2025 by Contiem Ltd

C. Brake lever

The brake levers (refer to [Fig FUNC-7](#)) are easily damaged. The lever is installed in the mount. A clamp bolt holds the mount. This bolt is not visible because it is found in the mount. The lever turns on a lever pivot bolt. The adjuster lock nut holds the brake cable. This lock nut adjusts the tension of the cable.

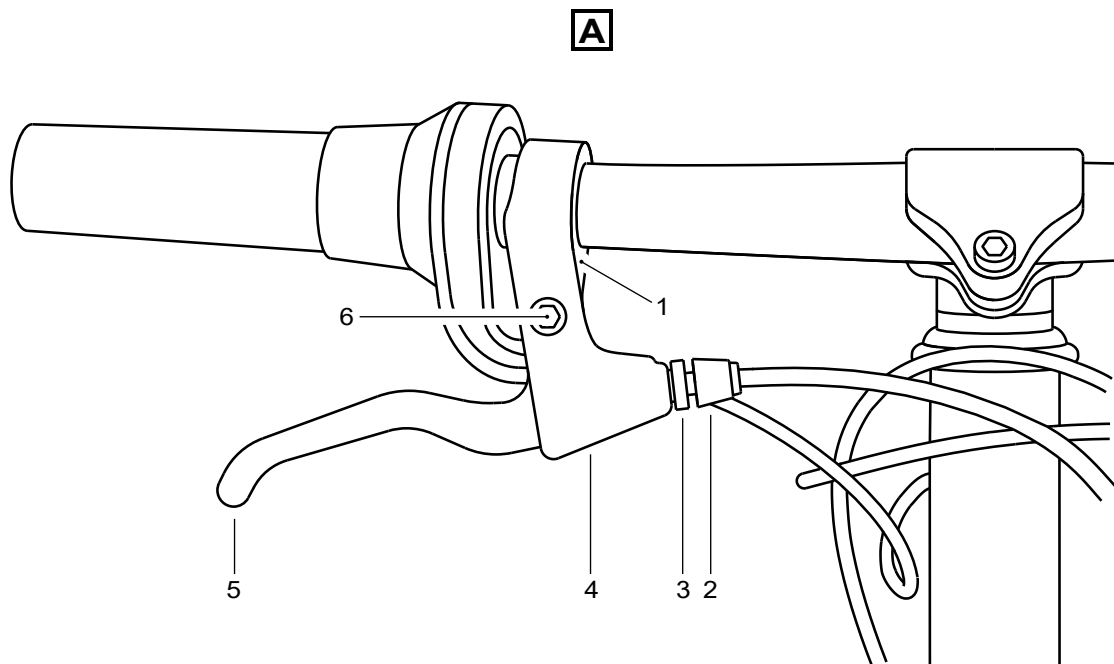
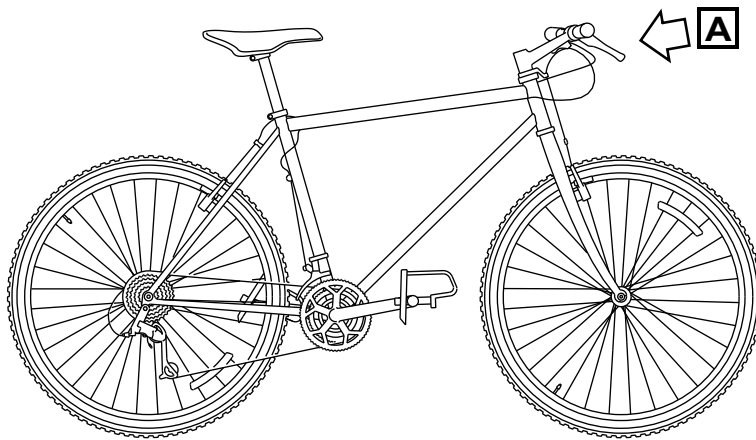

ICN-C0419-S1000D0381-001-01

Figure FUNC-7 Typical components of a mountain bicycle lever

DESCRIPTION OF FUNCTION

2018-03-01

Page FUNC-13

CTM23-10-10

Copyright (C) 2025 by Contiem Ltd

The left brake lever holds the brake pads on the front wheel and the right brake pads hold the brakes on the rear wheel.

End of S1000DBIKE-AAA-DA1-00-00-00AA-041A-A

S1000DBIKE-AAA-DA2-00-00-00AA-041A-A

7. Steering

The steering on the bike is what enables the bike to manoeuvre in a given direction during travel. The steering system on the bike is made of three parts, they are:

- [Para 7.A.](#) The handlebar
- [Para 7.B.](#) The headset
- [Para 7.C.](#) The stem

A. Handlebar

This consists of a horizontal bar attached to the stem with handgrips at the end. Brake levers and shifters are also attached to this bar although they do not have any part in the steering mechanism. The handlebars manoeuvrability is a sideways swivelling action. The handlebars themselves do not provide this swivelling, the headset (also known as the steering tube) is the mechanism that enables the handlebars to swivel.

B. Headset

This mechanism is situated in front of the frame and connects the front fork to the stem and handlebars. The headset allows the handlebars to swivel left and right for steering purposes.

For a full description of the headset, refer to [S1000DBIKE-AAA-DA2-30-00-00AA-041A-A](#) .

C. Stem

The stem is a piece that attaches the handlebar to the steering tube. Basically the stem is just a threaded stem bolt situated inside the steerer tube and is what attaches the handlebars to the headset.

End of S1000DBIKE-AAA-DA2-00-00-00AA-041A-A

S1000DBIKE-AAA-DA2-30-00-00AA-041A-A

8. Headset

The headset (refer to [Fig FUNC-8](#)) is a pair of bearings on the two ends of the head tube of the frame. These bearings permit the fork to turn rearward and forward (for example, to let the rider turn the handlebars for the steering).

The headset (refer to [Fig FUNC-8](#)) includes the parts that follow:

- The bearing races that push into the head tube
- a bearing race that pushes on the fork steerer tube
- an adjustable upper race
- two sets of ball bearings

A headset has cups that are pushed into the head tube and a ring on the fork. All three must be fully parallel. It is usually necessary to remove rough paint to get all three fully parallel.

The upper race installs onto the steerer tube with a thread. A locknut is used to safety the upper race.

A clamp bolt holds the stem to the steerer tube.

The fourth remaining bearing race is part of a nut that installs on the threaded top end of the fork. This is done after you install it in the head tube. It is sometimes necessary for some headsets to have more

thread at the top of the head tube. If the fork is too long, the spacer rings can be installed. If it is too short, there is a limit to the number of headsets you can use.

For an illustration of the parts of the headset (refer to [Fig FUNC-8](#)).

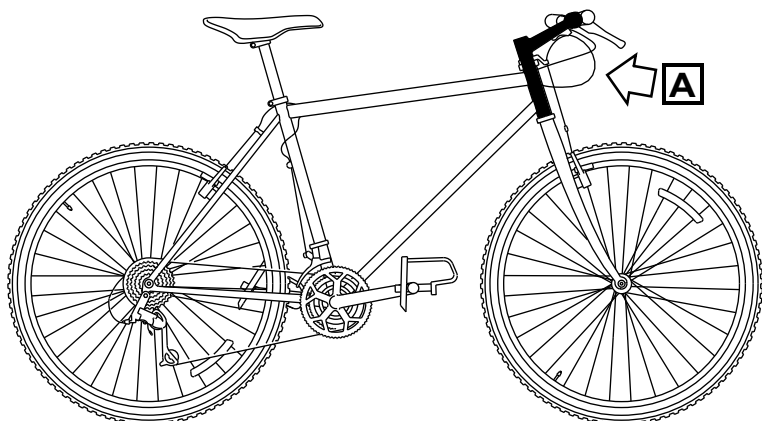

A

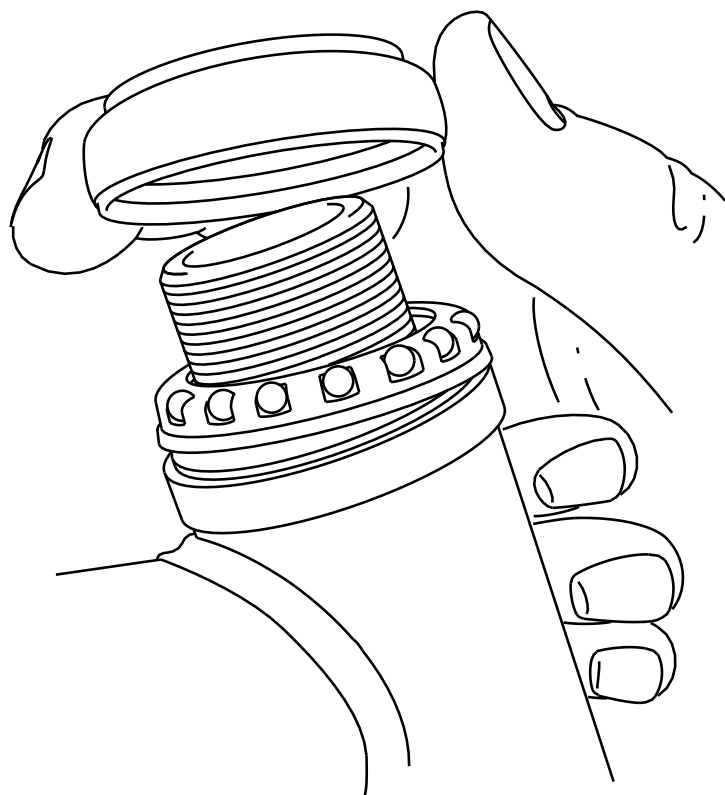

ICN-C0419-S1000D0391-001-01

Figure FUNC-8 Headset

CTM23-10-10

Copyright (C) 2025 by Contiem Ltd

DESCRIPTION OF FUNCTION

2018-03-01

Page FUNC-16

End of S1000DBIKE-AAA-DA2-30-00-00AA-041A-A

S1000DBIKE-AAA-DA3-00-00-00AA-041A-A

9. The bicycle frame

The frame is the skeleton, the primary part of your bicycle. Its structure makes the bicycle resistant to large forces.

The initial frames (refer to [Fig FUNC-9](#)) were tubes of aluminum or steel welded together.

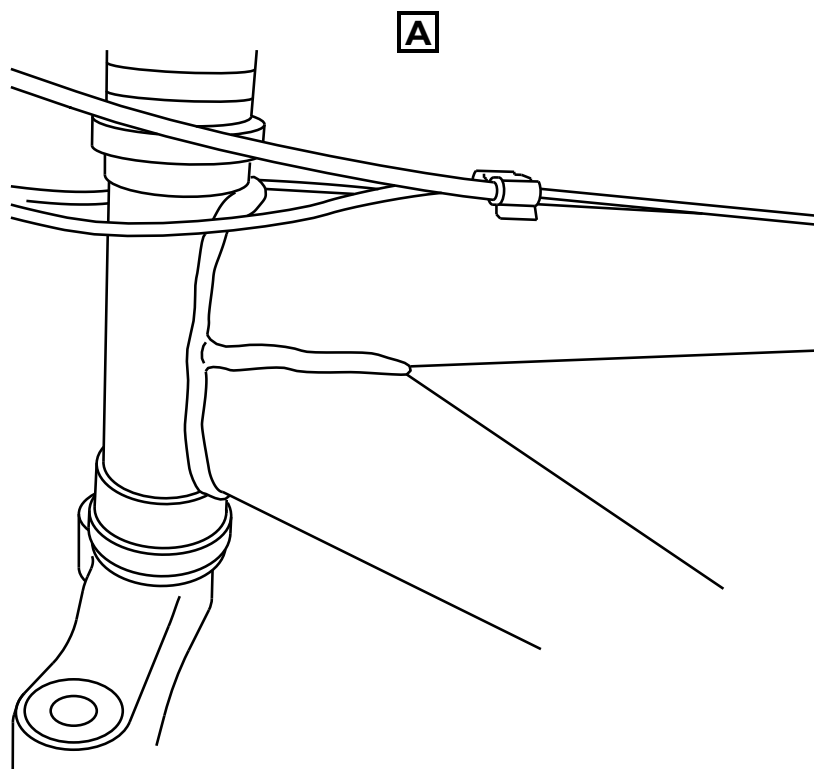
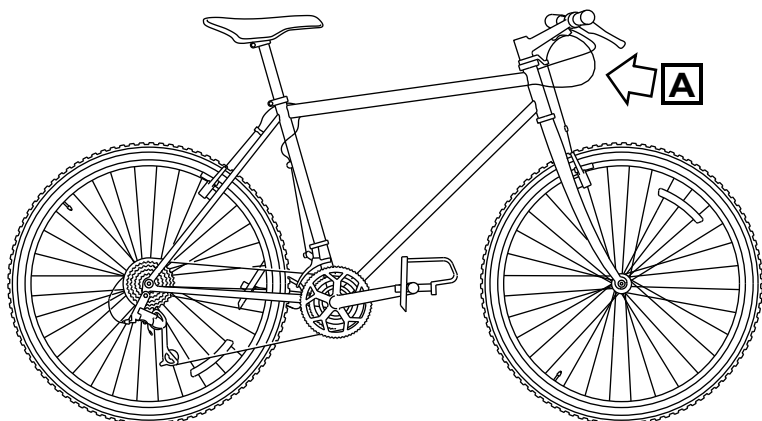

ICN-C0419-S1000D0394-001-01

Figure FUNC-9 Welded frame joints

DESCRIPTION OF FUNCTION

2018-03-01

Page FUNC-18

CTM23-10-10

Copyright (C) 2025 by Contiem Ltd

Subsequent frames (refer to [Fig FUNC-10](#)) can be made out of a wide variety of materials, including aluminium, titanium, or chrome moly.

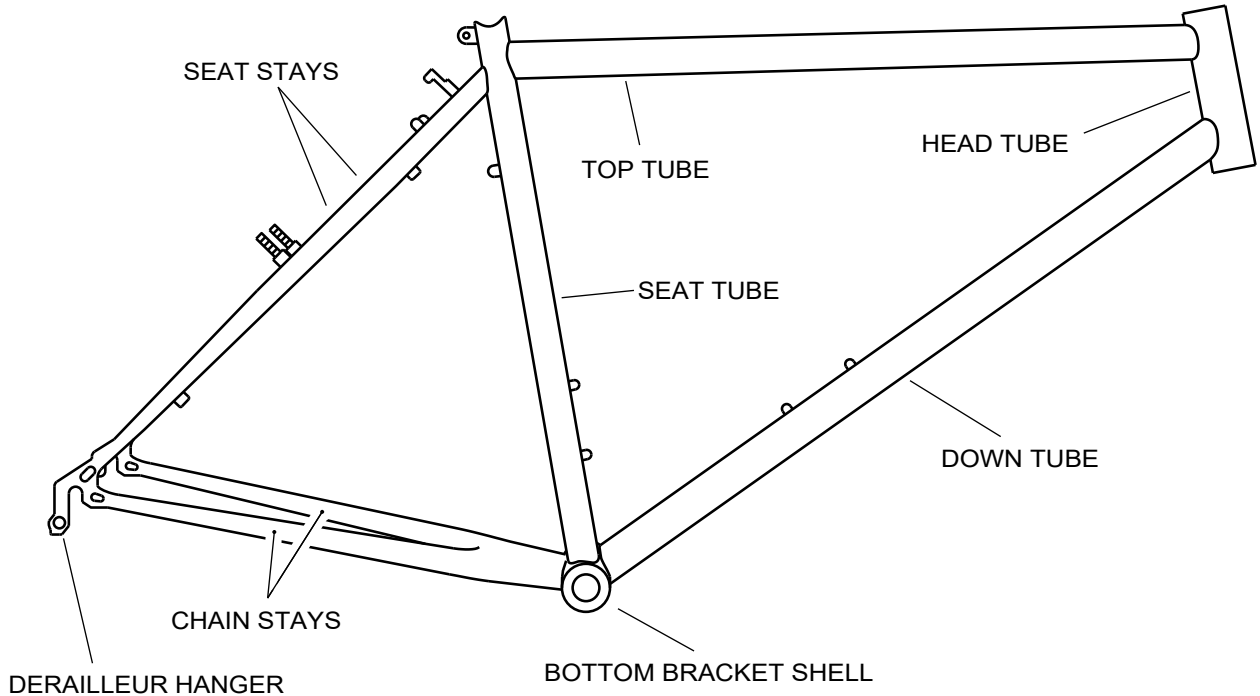

ICN-C0419-S1000D0393-001-01

Figure FUNC-10 Frame

Other Frames are different and can also be of different materials (for example, titanium or chrome moly). Some bicycle frames are of carbon fiber. To get this material, it is necessary to put sheets of carbon fiber cloth on foam forms and epoxy them in position. This procedure gives a very light, strong structure that can have different shapes.

The frame includes the parts that follow:

- the top tube (the higher bar of the bicycle frame)
- the down tube (the section of the frame that extends from the stem to the bottom bracket)
- the head tube (the part of the frame that the fork steerer tube goes through)
- the seat tube (the vertical part of the frame that is the rear of the front triangle and that is between the bottom bracket and the top tube)
- the seat stay (the tube that includes the distance between the seat tube and the rear dropouts)
- the chain stay (the tube that is the bottom part of the rear triangle)

End of S1000DBIKE-AAA-DA3-00-00-00AA-041A-A

S1000DBIKE-AAA-DA4-00-00-00AA-041A-A

10. Drive train

The drive train is the group of components that are necessary for the operation of the bicycle. The drive train is the primary system for the movement of the bicycle. A typical drive train has the chain wheels, the chain, the pedals and the saddle.

Since the drive train has many components, it is necessary to do a regular maintenance. The drive train maintenance is easy and the users can disassemble and assemble each part of the drive train. Because of this, when one part is defective, it is possible to remove and replace it with a new one.

End of S1000DBIKE-AAA-DA4-00-00-00AA-041A-A

S1000DBIKE-AAA-DA5-00-00-00AA-041A-A

11. Gears

The gears include the mechanism, the hubs and the shifters.

The description of the mechanisms is given in [S1000DBIKE-AAA-DA5-10-00-00AA-041A-A](#)

The description of the shifters is given in [S1000DBIKE-AAA-DA5-30-00-00AA-041A-A](#)

The bicycles of these days can have 27 gears or more. The mountain bikes use a set that includes:

- Three socket sprockets of different dimension on the front
- Nine socket sprockets of different dimensions at the rear

This set gives the gear ratios.

The shifters installed on the handlebars change the gears and operate the mechanisms (also known as derailleurs). These derailleurs are cable-actuated mechanisms. They move the chain from the different sprockets.

The hub is the center of the wheel and contains the axle and bearings.

The gears let the rider crank at the pedals at a constant movement on slopes of different angles.

End of S1000DBIKE-AAA-DA5-00-00-00AA-041A-A

S1000DBIKE-AAA-DA5-10-00-00AA-041A-A

12. Derailleur

There are two different types of derailleur, the front and the rear. Derailleur gears are a variable-ratio transmission system commonly used on bicycles. (Derailleur)Shifters are the mechanism used to move between gears. (Shifters)

A. Front derailleur

The front derailleur (refer to [Fig FUNC-11](#)) contains two types of screws to keep the movement of the derailleur to a minimum. These screws are:

- the stop screw low-gear
- the stop screw high-gear

The function of these screws is to prevent the rider from over shifting . If this occurs, the chain will go out of the chain wheel.

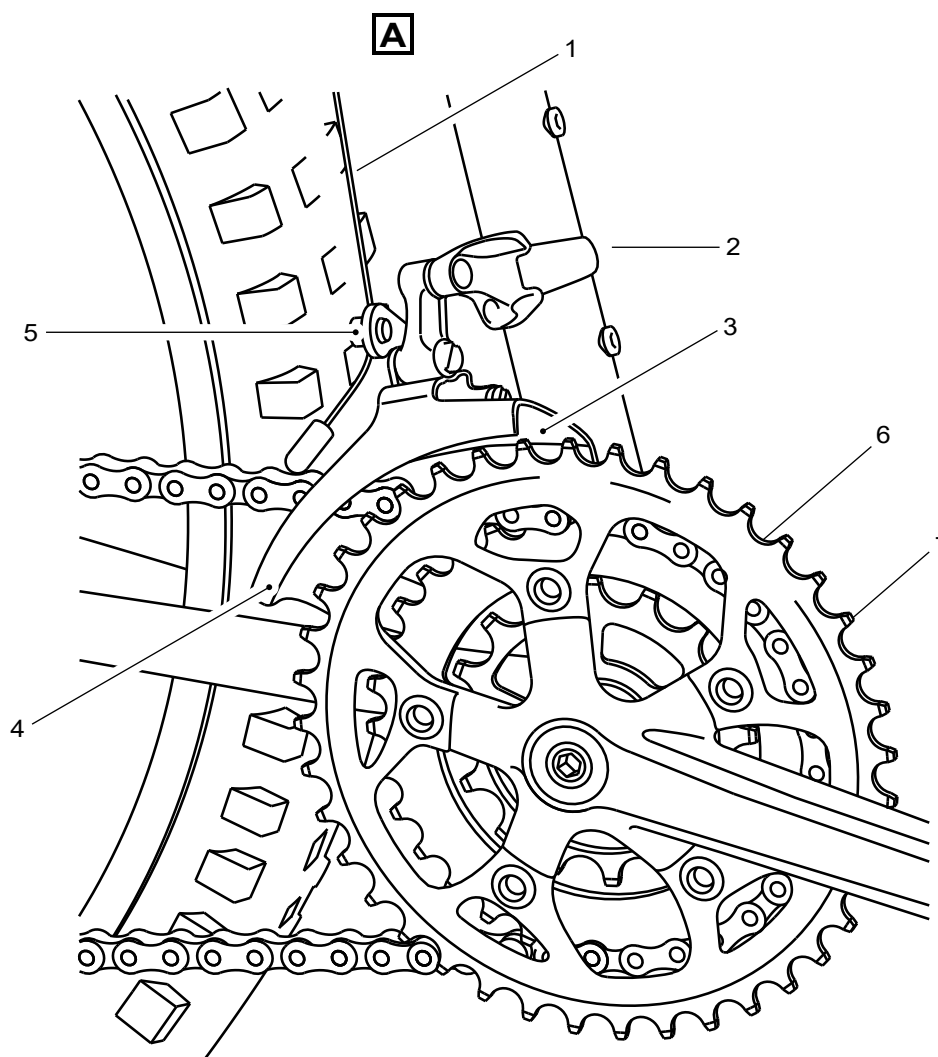
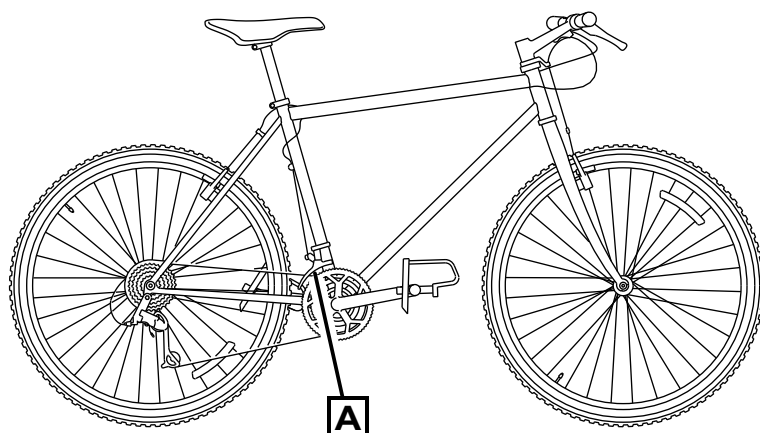

ICN-C0419-S1000D0396-001-01

Figure FUNC-11 Front derailleur

DESCRIPTION OF FUNCTION

2018-03-01

Page FUNC-21

CTM23-10-10

Copyright (C) 2025 by Contiem Ltd

The derailleur is installed on the bicycle seat tube with a clamp and is parallel to the three front sprockets.

The shift cable is connected between the shifters on the handle bars and the cable clamp bolt on the front derailleur. This operates the derailleur. On the sprockets there is an inner and outer cage. The clamp attaches the cage.

B. Rear derailleur

The rear derailleur (refer to [Fig FUNC-12](#)) section contains the sprockets for the different gear changes. When the cable clamp bolt is tight, it holds the shift cable in its position. A screwed bolt holds the tension wheel.

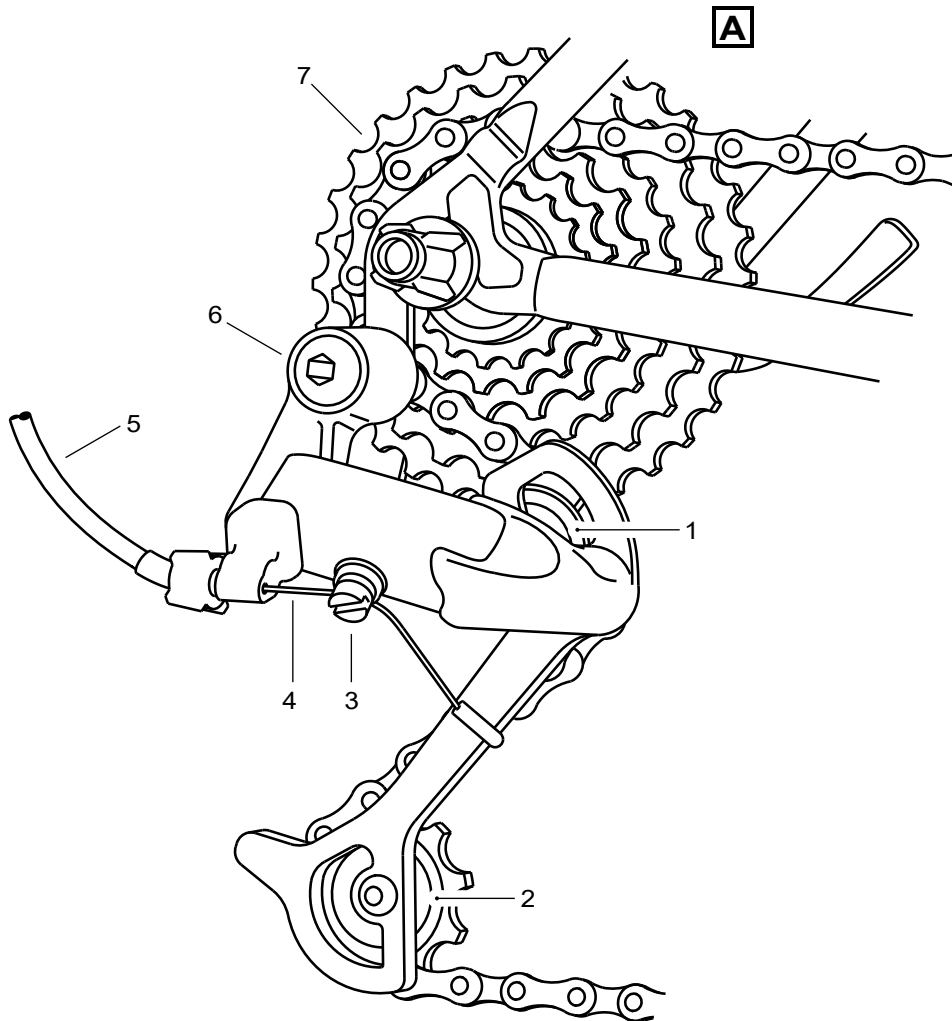
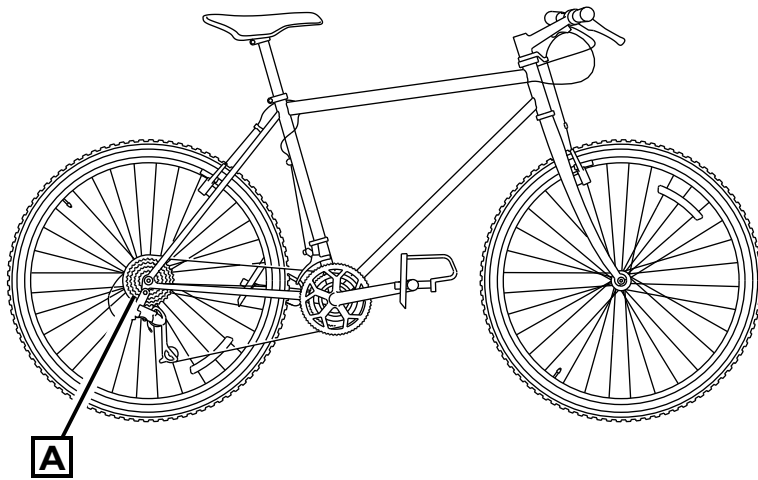

ICN-C0419-S1000D0397-001-01

Figure FUNC-12 Rear derailleur

DESCRIPTION OF FUNCTION

2018-03-01

Page FUNC-23

CTM23-10-10

Copyright (C) 2025 by Contiem Ltd

The derailleur mounting bolt connects the derailleur to the frame. When the user attaches this bolt, this makes sure that the cage plates are parallel with the chain rings.

The guide wheel has the function to move the chain with the derailleur. It moves the chain from one sprocket to the other. The guide wheel must not move on its axis. If this occurs, there will be wear on the wheel. The position of the guide wheel is below the largest sprocket.

End of S1000DBIKE-AAA-DA5-10-00-00AA-041A-A

S1000DBIKE-AAA-DA5-30-00-00AA-041A-A

13. Shifters

The thumb shifter is a usual type in modern bicycles. It is possible to adjust this type of shifter for operation in the index position or in the friction position. The differences between the two are:

- The index shifters change the gears with a click of a lever.
- The friction shifters hold the derailleur in its position by friction.

The thumb shifters (refer to [Fig FUNC-13](#)) are held on the bicycle with a screw. The paragraph that follows gives a description of a thumb shifter.

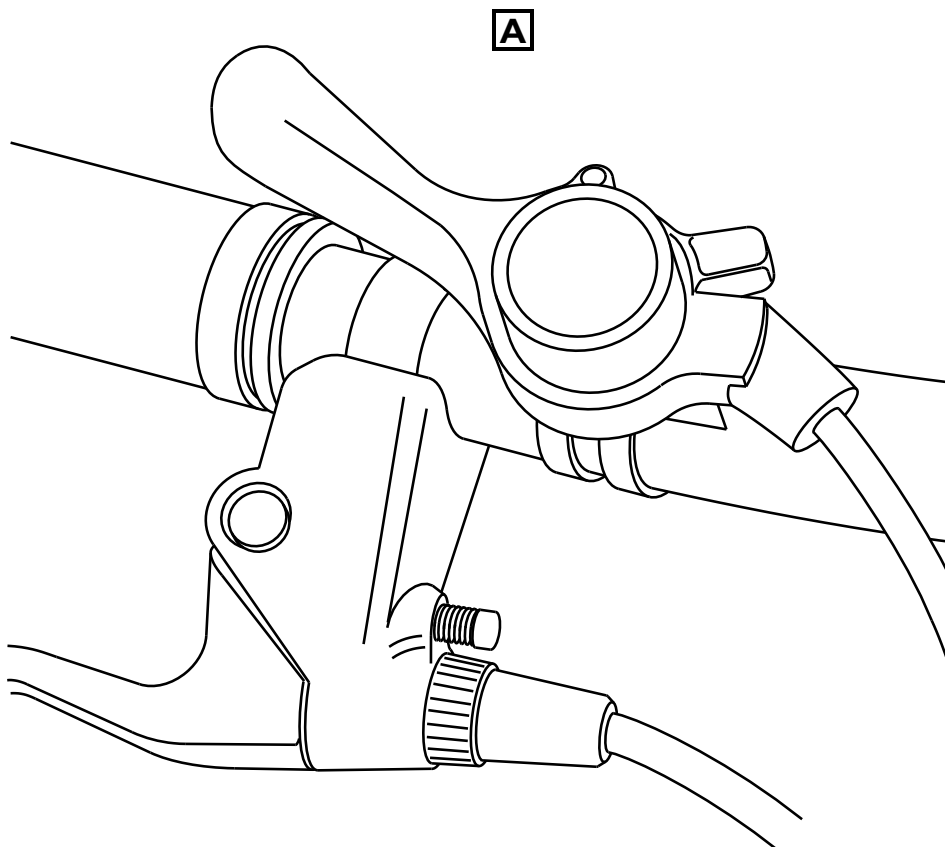
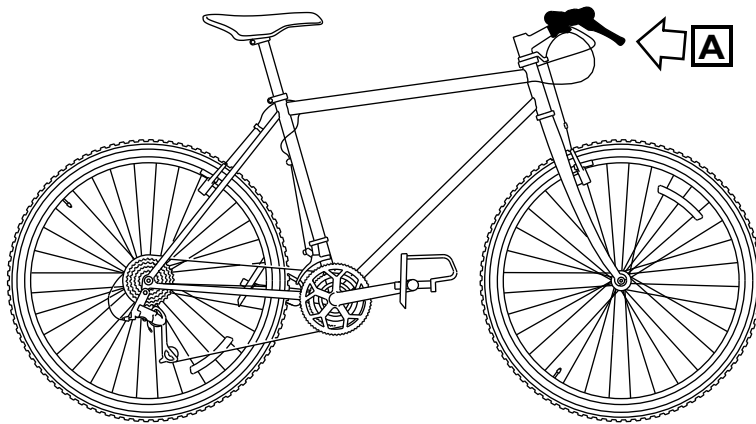

ICN-C0419-S1000D0405-001-01

Figure FUNC-13 Thumb shifter index type

DESCRIPTION OF FUNCTION

2018-03-01

Page FUNC-25

CTM23-10-10

Copyright (C) 2025 by Contiem Ltd

14. How a thumb shifter is made up

A wing nut (refer to [Fig FUNC-14](#)) from the top of the lever holds the thumb shifter. The lever is on top of the mount and the mount is on the handle bar with a nut. To remove the mount, it is necessary to loosen the nut of two turns (refer to [Fig FUNC-15](#)), then the mount can move from the handle bar from the top of the lever. The lever sits on top of the mount and the mount is fixed into place on the handle bar by a nut.

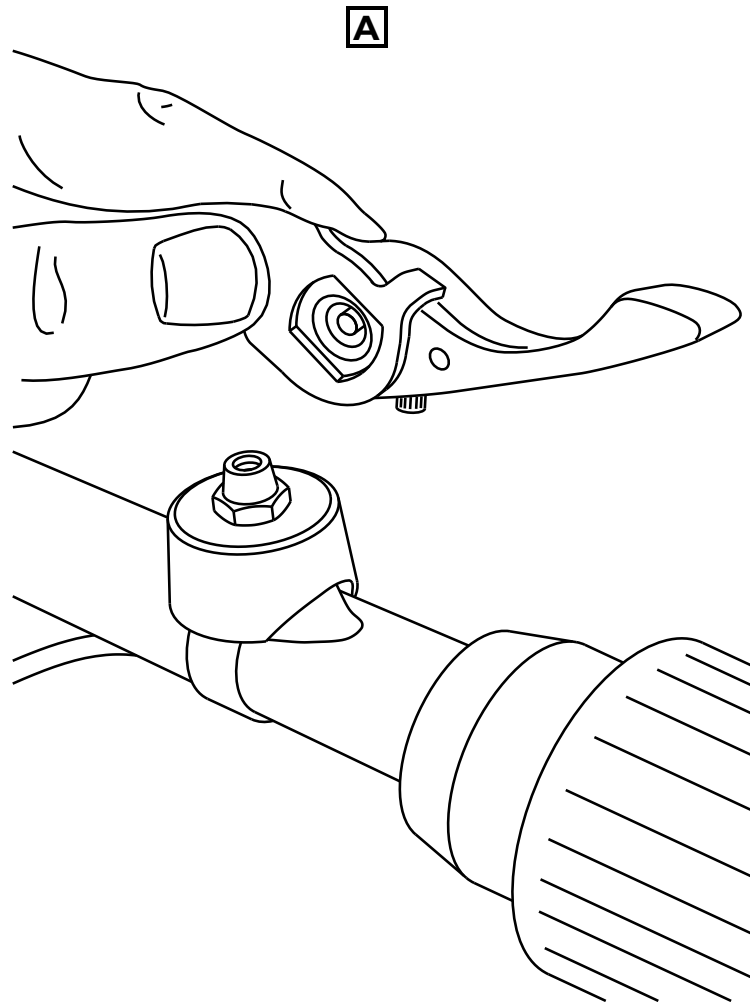
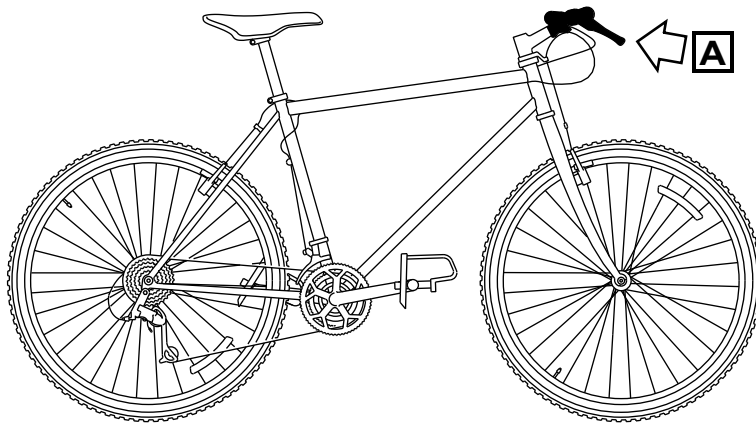

ICN-C0419-S1000D0402-001-01

Figure FUNC-14 Unscrew wingnut

DESCRIPTION OF FUNCTION

2018-03-01

Page FUNC-27

CTM23-10-10

Copyright (C) 2025 by Contiem Ltd

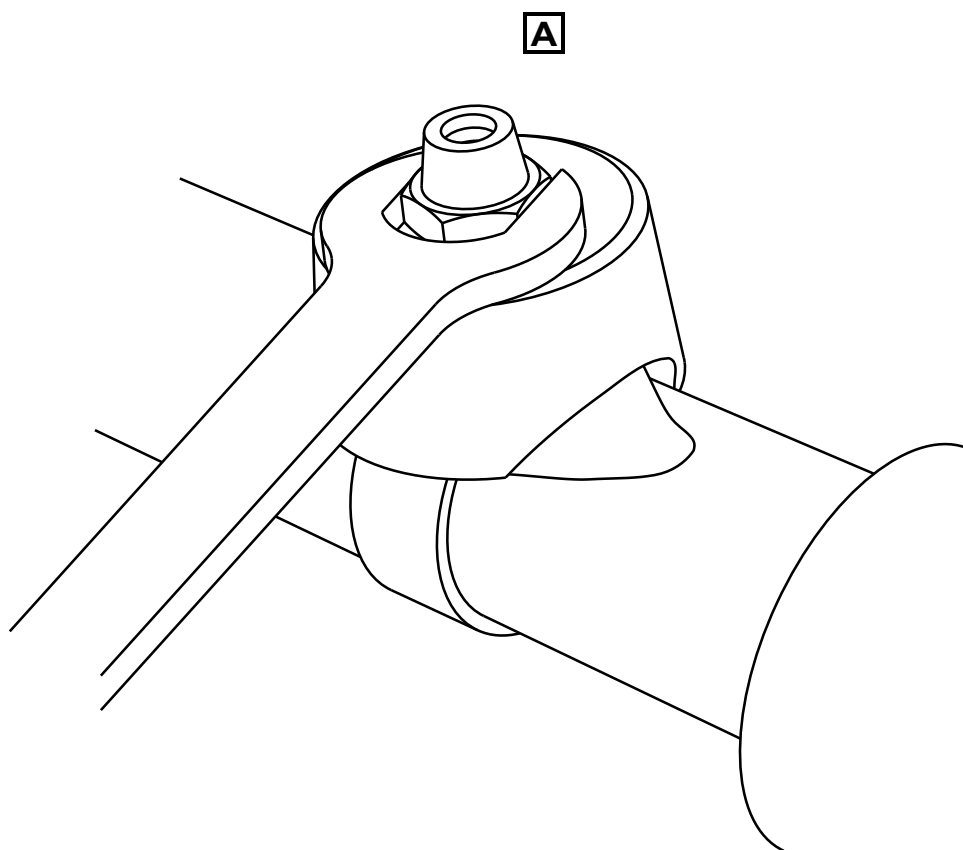
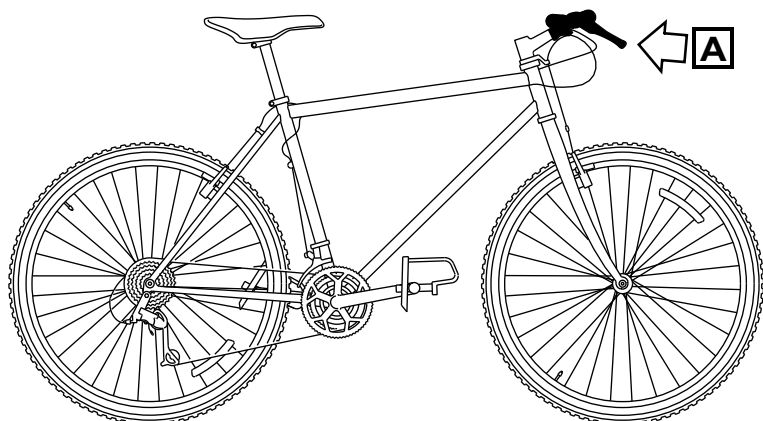

ICN-C0419-S1000D0403-001-01

Figure FUNC-15 Loosen the nut

On modern models of this shifter, there is a clamp bolt that holds the shifter in its position (refer to [Fig FUNC-16](#)). The user can loosen the clamp bolt with an applicable tool. This lets the shifter release the handlebar.

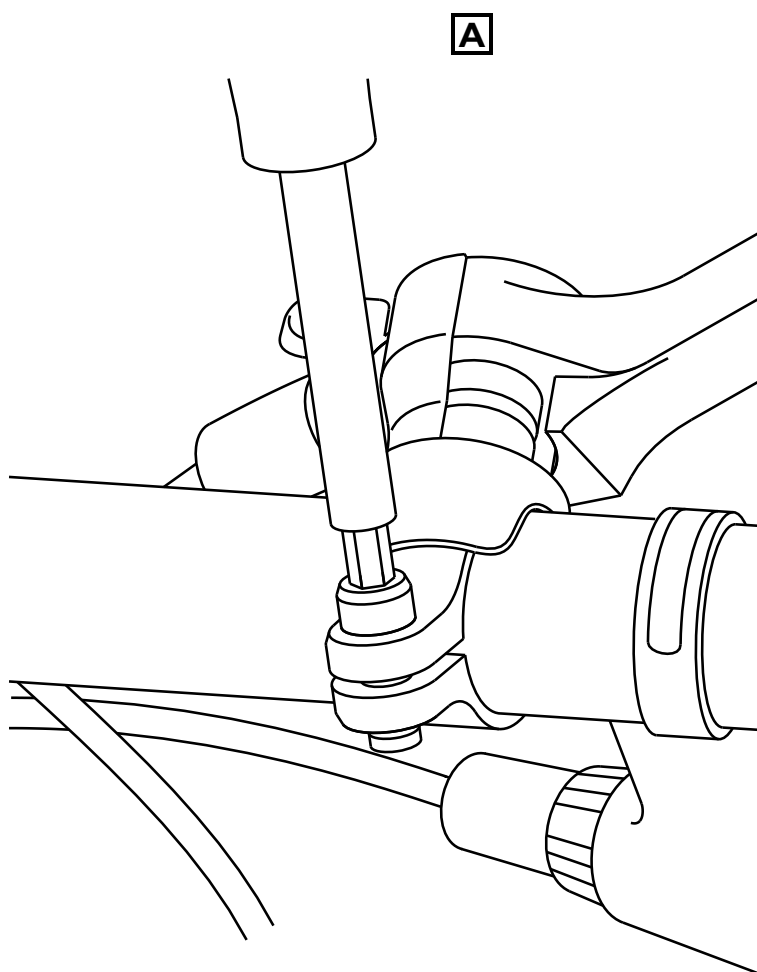
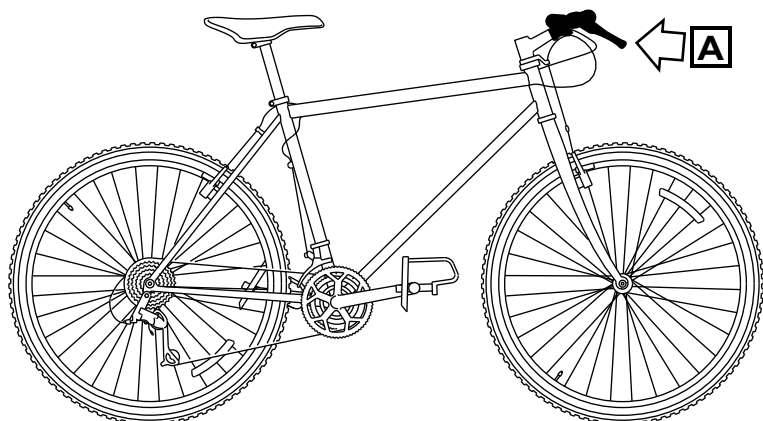

ICN-C0419-S1000D0404-001-01

Figure FUNC-16 Loosen the shifter clamp bolt

DESCRIPTION OF FUNCTION

2018-03-01

Page FUNC-30

CTM23-10-10

Copyright (C) 2025 by Contiem Ltd

End of S1000DBIKE-AAA-DA5-30-00-00AA-041A-A
End of DESCRIPTION OF FUNCTION

INTENTIONALLY BLANK

Technical description

S1000DBIKE-AAA-DA3-00-00-00AA-041A-A

1. The bicycle frame

The frame is the skeleton, the primary part of your bicycle. Its structure makes the bicycle resistant to large forces.

The initial frames (refer to [Fig FUNC-9](#)) were tubes of aluminum or steel welded together.

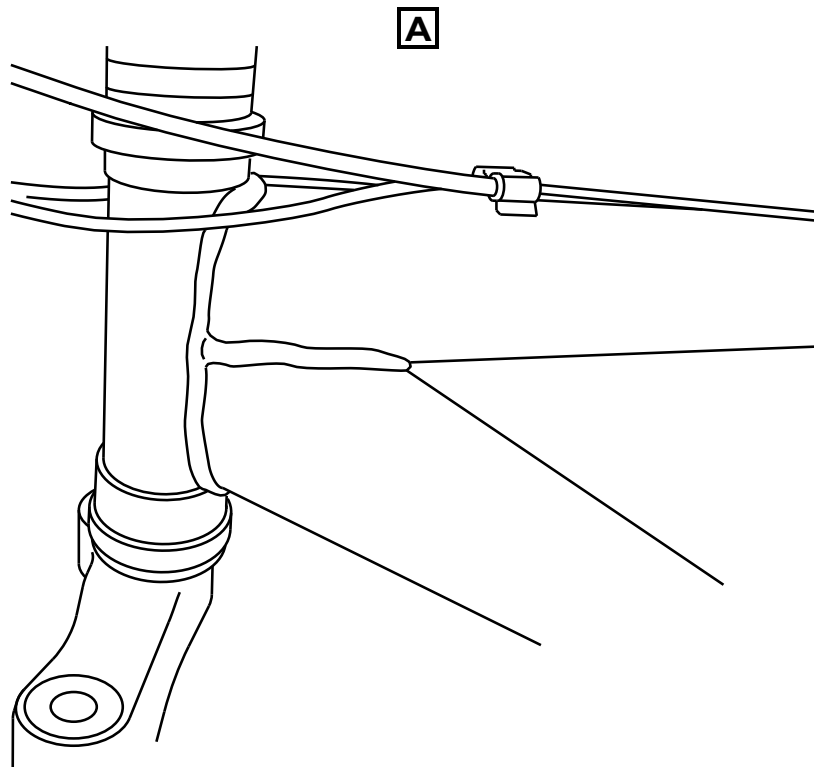
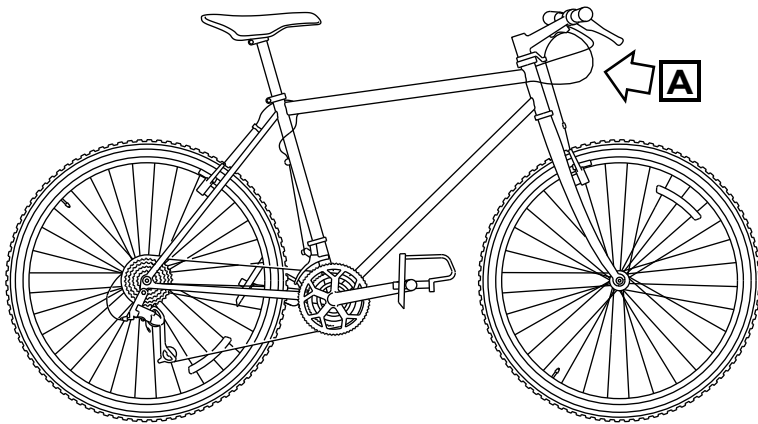

ICN-C0419-S1000D0394-001-01

Figure DESC-1 Welded frame joints

TECHNICAL DESCRIPTION

2018-03-01

Page DESC-2

CTM23-10-10

Copyright (C) 2025 by Contiem Ltd

Subsequent frames (refer to [Fig FUNC-10](#)) can be made out of a wide variety of materials, including aluminium, titanium, or chrome moly.

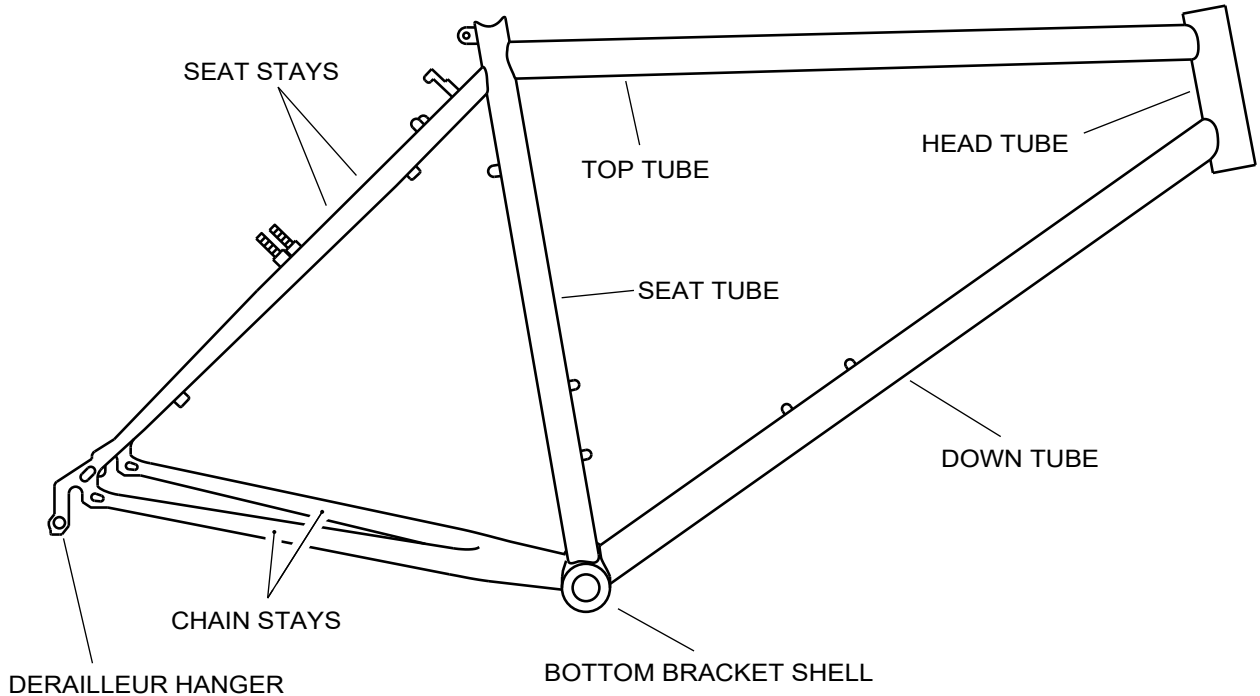

ICN-C0419-S1000D0393-001-01

Figure DESC-2 Frame

Other Frames are different and can also be of different materials (for example, titanium or chrome moly). Some bicycle frames are of carbon fiber. To get this material, it is necessary to put sheets of carbon fiber cloth on foam forms and epoxy them in position. This procedure gives a very light, strong structure that can have different shapes.

The frame includes the parts that follow:

- the top tube (the higher bar of the bicycle frame)
- the down tube (the section of the frame that extends from the stem to the bottom bracket)
- the head tube (the part of the frame that the fork steerer tube goes through)
- the seat tube (the vertical part of the frame that is the rear of the front triangle and that is between the bottom bracket and the top tube)
- the seat stay (the tube that includes the distance between the seat tube and the rear dropouts)
- the chain stay (the tube that is the bottom part of the rear triangle)

End of S1000DBIKE-AAA-DA3-00-00-00AA-041A-A

S1000DBIKE-AAA-DA4-00-00-00AA-041A-A

2. Drive train

The drive train is the group of components that are necessary for the operation of the bicycle. The drive train is the primary system for the movement of the bicycle. A typical drive train has the chain wheels, the chain, the pedals and the saddle.

Since the drive train has many components, it is necessary to do a regular maintenance. The drive train maintenance is easy and the users can disassemble and assemble each part of the drive train. Because of this, when one part is defective, it is possible to remove and replace it with a new one.

End of S1000DBIKE-AAA-DA4-00-00-00AA-041A-A

S1000DBIKE-AAA-DA5-00-00-00AA-041A-A

3. Gears

The gears include the mechanism, the hubs and the shifters.

The description of the mechanisms is given in [S1000DBIKE-AAA-DA5-10-00-00AA-041A-A](#)

The description of the shifters is given in [S1000DBIKE-AAA-DA5-30-00-00AA-041A-A](#)

The bicycles of these days can have 27 gears or more. The mountain bikes use a set that includes:

- Three socket sprockets of different dimension on the front
- Nine socket sprockets of different dimensions at the rear

This set gives the gear ratios.

The shifters installed on the handlebars change the gears and operate the mechanisms (also known as derailleurs). These derailleurs are cable-actuated mechanisms. They move the chain from the different sprockets.

The hub is the center of the wheel and contains the axle and bearings.

The gears let the rider crank at the pedals at a constant movement on slopes of different angles.

End of S1000DBIKE-AAA-DA5-00-00-00AA-041A-A

S1000DBIKE-AAA-DA5-10-00-00AA-041A-A

4. Derailleur

There are two different types of derailleur, the front and the rear. Derailleur gears are a variable-ratio transmission system commonly used on bicycles. (Derailleur)Shifters are the mechanism used to move between gears. (Shifters)

A. Front derailleur

The front derailleur (refer to [Fig FUNC-11](#)) contains two types of screws to keep the movement of the derailleur to a minimum. These screws are:

- the stop screw low-gear
- the stop screw high-gear

The function of these screws is to prevent the rider from over shifting . If this occurs, the chain will go out of the chain wheel.

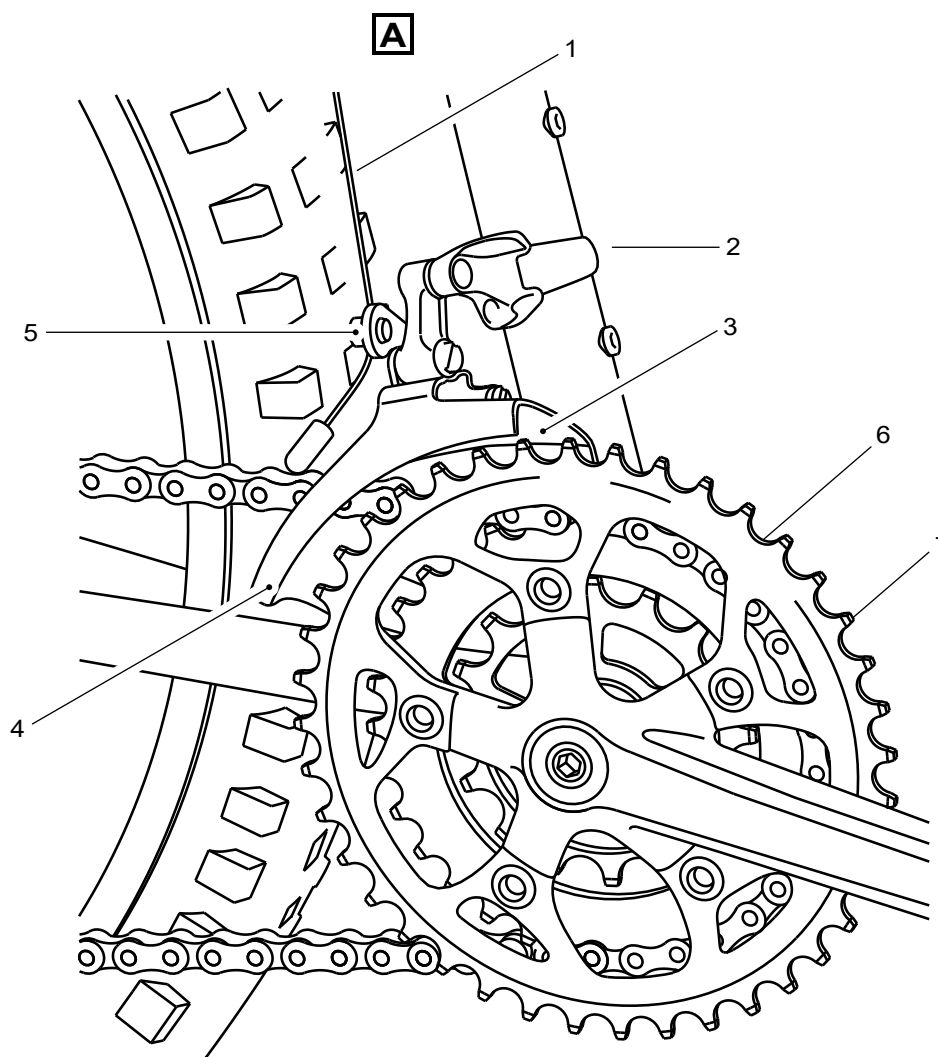
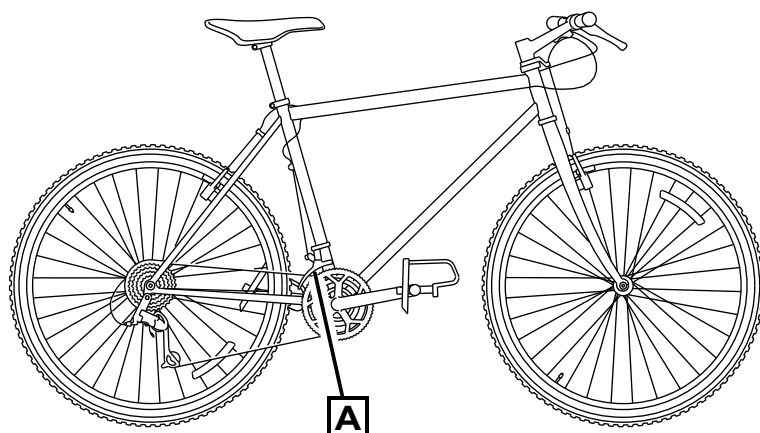

ICN-C0419-S1000D0396-001-01

Figure DESC-3 Front derailleur

TECHNICAL DESCRIPTION

2018-03-01

Page DESC-5

CTM23-10-10

Copyright (C) 2025 by Contiem Ltd

The derailleur is installed on the bicycle seat tube with a clamp and is parallel to the three front sprockets.

The shift cable is connected between the shifters on the handle bars and the cable clamp bolt on the front derailleur. This operates the derailleur. On the sprockets there is an inner and outer cage. The clamp attaches the cage.

B. Rear derailleur

The rear derailleur (refer to [Fig FUNC-12](#)) section contains the sprockets for the different gear changes. When the cable clamp bolt is tight, it holds the shift cable in its position. A screwed bolt holds the tension wheel.

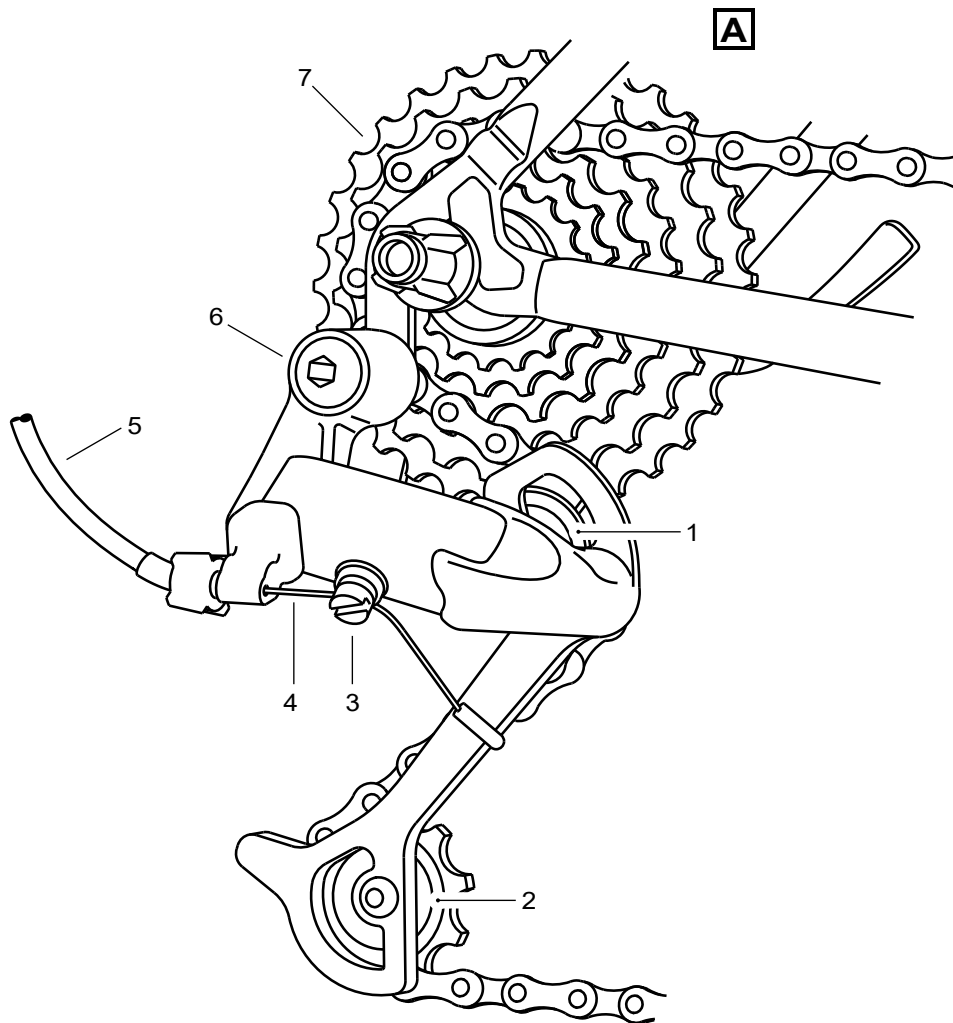
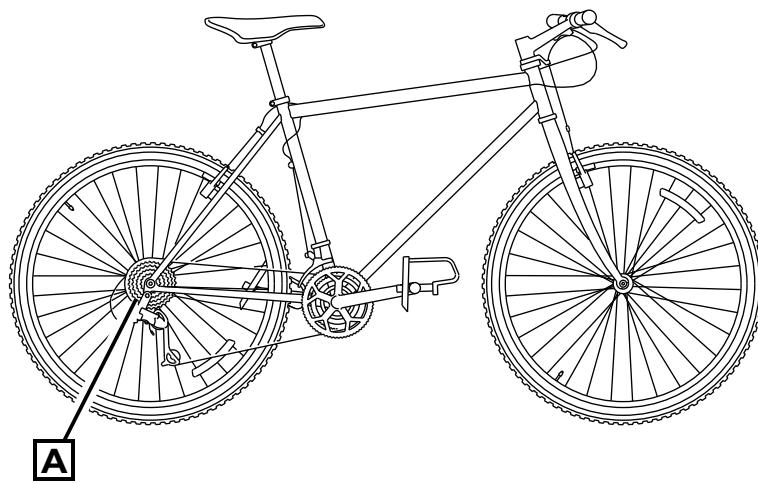

ICN-C0419-S1000D0397-001-01

Figure DESC-4 Rear derailleur

TECHNICAL DESCRIPTION

2018-03-01

Page DESC-7

CTM23-10-10

Copyright (C) 2025 by Contiem Ltd

The derailleur mounting bolt connects the derailleur to the frame. When the user attaches this bolt, this makes sure that the cage plates are parallel with the chain rings.

The guide wheel has the function to move the chain with the derailleur. It moves the chain from one sprocket to the other. The guide wheel must not move on its axis. If this occurs, there will be wear on the wheel. The position of the guide wheel is below the largest sprocket.

End of S1000DBIKE-AAA-DA5-10-00-00AA-041A-A

S1000DBIKE-AAA-DA5-30-00-00AA-041A-A

5. Shifters

The thumb shifter is a usual type in modern bicycles. It is possible to adjust this type of shifter for operation in the index position or in the friction position. The differences between the two are:

- The index shifters change the gears with a click of a lever.
- The friction shifters hold the derailleur in its position by friction.

The thumb shifters (refer to [Fig FUNC-13](#)) are held on the bicycle with a screw. The paragraph that follows gives a description of a thumb shifter.

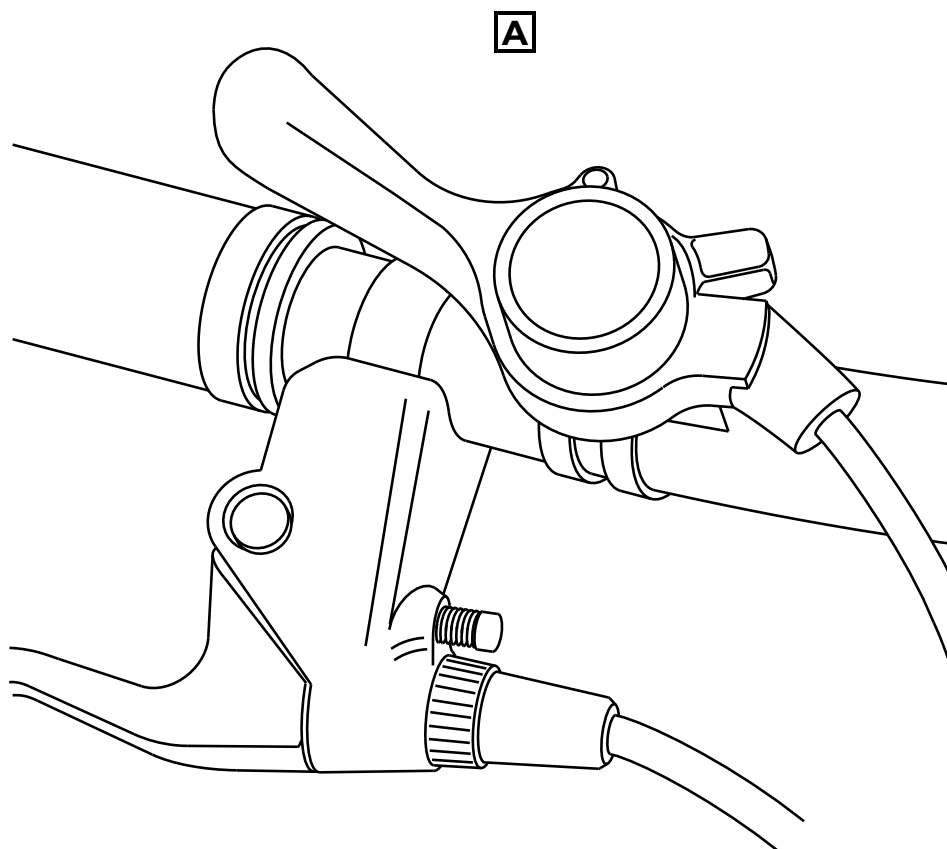
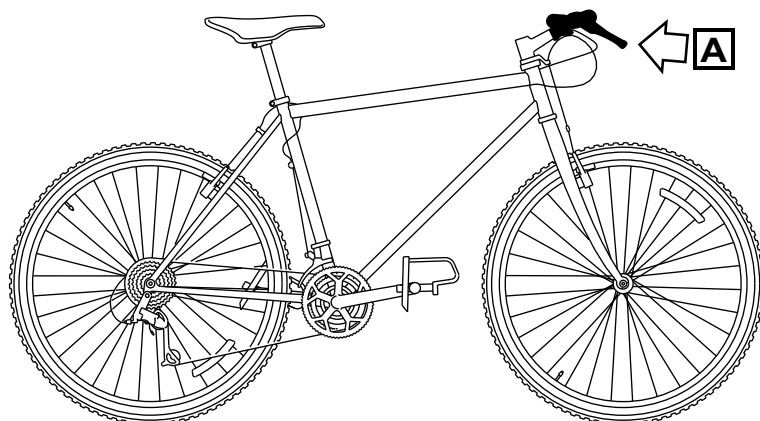

ICN-C0419-S1000D0405-001-01

Figure DESC-5 Thumb shifter index type

TECHNICAL DESCRIPTION

2018-03-01

Page DESC-9

CTM23-10-10

Copyright (C) 2025 by Contiem Ltd

6. How a thumb shifter is made up

A wing nut (refer to [Fig FUNC-14](#)) from the top of the lever holds the thumb shifter. The lever is on top of the mount and the mount is on the handle bar with a nut. To remove the mount, it is necessary to loosen the nut of two turns (refer to [Fig FUNC-15](#)), then the mount can move from the handle bar from the top of the lever. The lever sits on top of the mount and the mount is fixed into place on the handle bar by a nut.

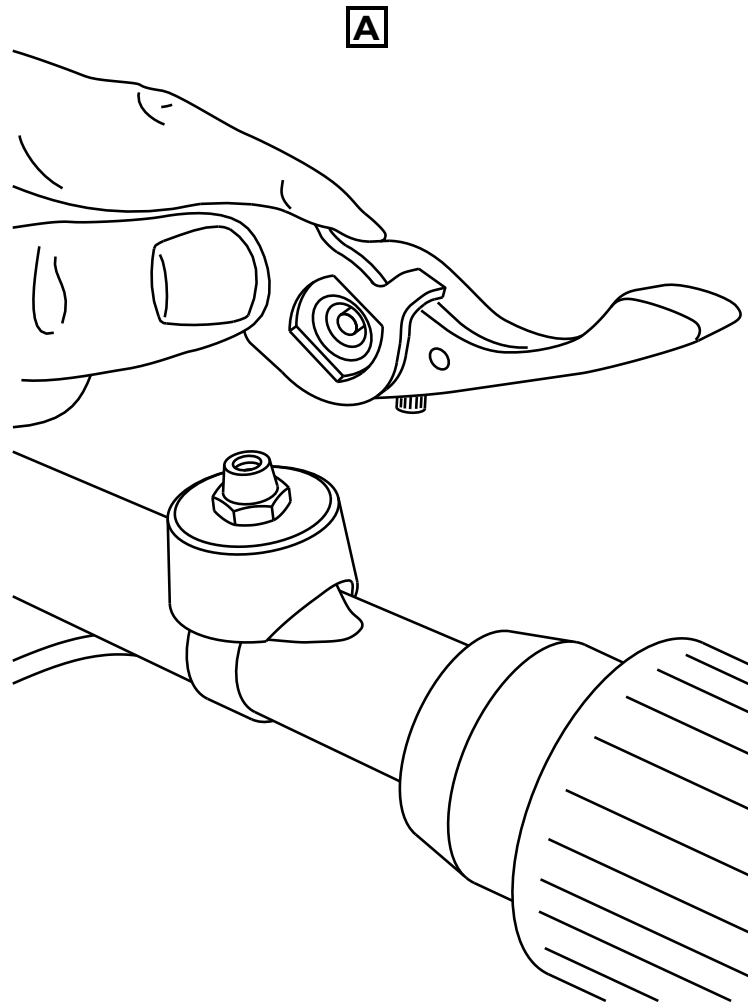
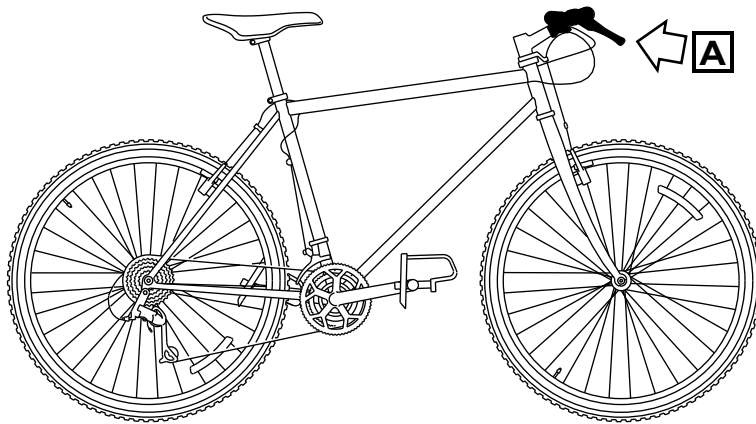

ICN-C0419-S1000D0402-001-01

Figure DESC-6 Unscrew wingnut

TECHNICAL DESCRIPTION

2018-03-01

Page DESC-11

CTM23-10-10

Copyright (C) 2025 by Contiem Ltd

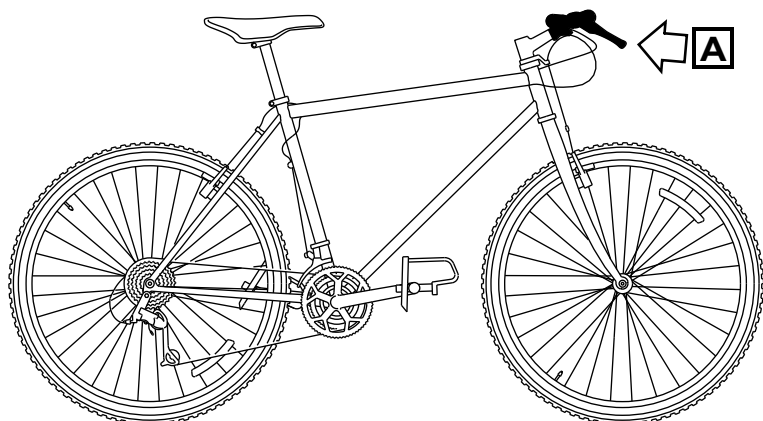

A

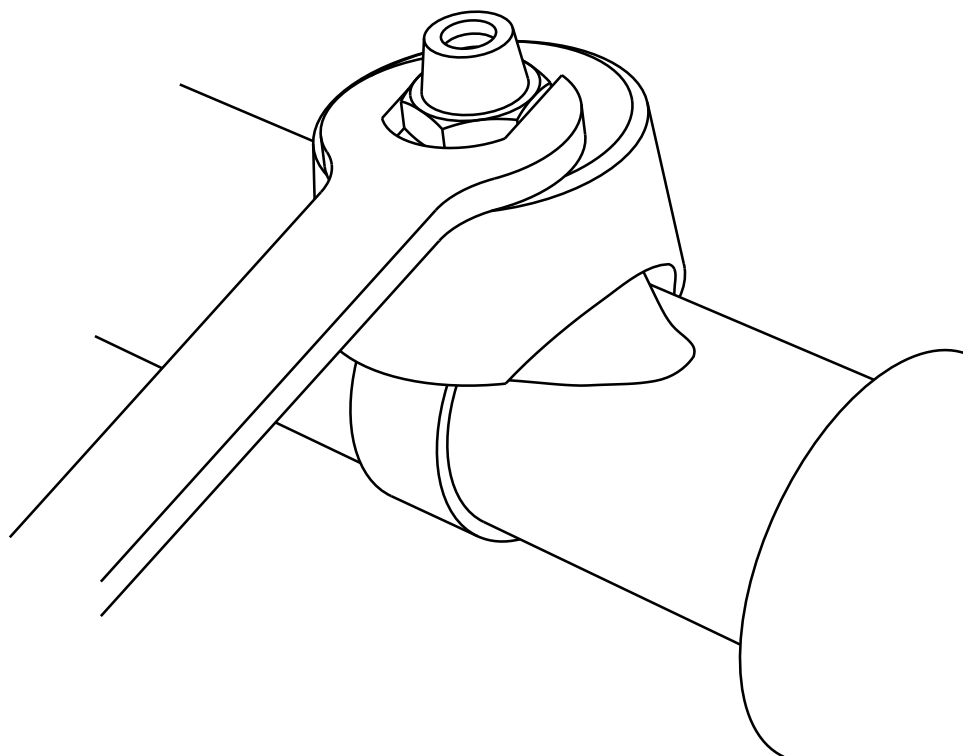

ICN-C0419-S1000D0403-001-01

Figure DESC-7 Loosen the nut

On modern models of this shifter, there is a clamp bolt that holds the shifter in its position (refer to [Fig FUNC-16](#)). The user can loosen the clamp bolt with an applicable tool. This lets the shifter release the handlebar.

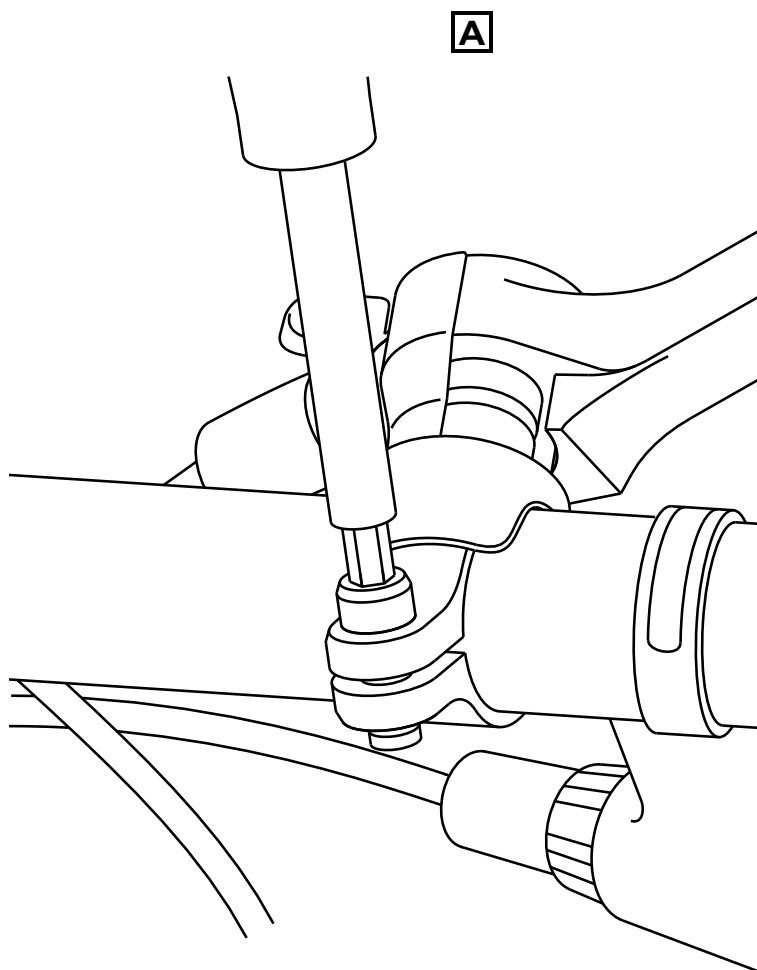
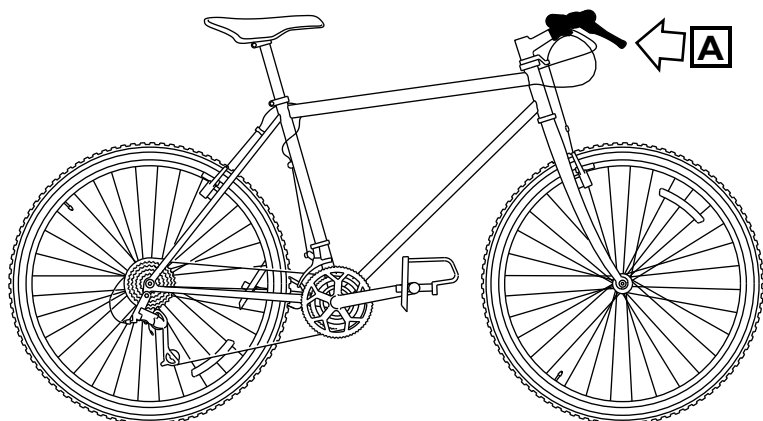

ICN-C0419-S1000D0404-001-01

Figure DESC-8 Loosen the shifter clamp bolt

End of S1000DBIKE-AAA-DA5-30-00-00AA-041A-A

End of TECHNICAL DESCRIPTION

INTENTIONALLY BLANK

Diagrams and schematics

S1000DLIGHTING-AAA-D00-00-00-00AA-040A-A

1. Lighting system

The illustration that follows (see [Fig SCHEM-1](#)) shows the lighting system of the bicycle.

The lighting system is equipped with special high beam lighting. Do not use special high beam lighting when bicycling on roads during winter months.

The lighting system is faulty and will be replaced by 2013-03-15.

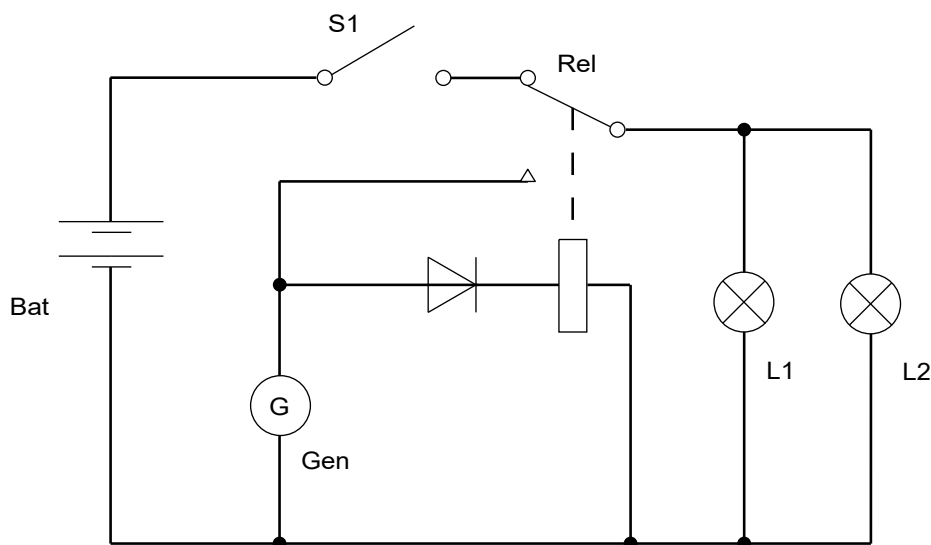

ICN-C0419-S1000D0392-001-01

Figure SCHEM-1 Lighting system

Component Maintenance Publication (CMP) AIR TRANSPORT ASSOCIATION OF AMERICA (ATA)
Illustrated Parts List (IPD)

Warning (symbol 1) Caution (symbol 2)

End of S1000DLIGHTING-AAA-D00-00-00-00AA-040A-A

End of DIAGRAMS AND SCHEMATICS

End of FUNCTIONAL AND TECHNICAL DESCRIPTION

INTENTIONALLY BLANK

Maintenance and servicing

Task sets

Table TS-1 Support equipment

Name/Alternate name	Identification/Reference	MFR	Quantity	Remarks
(1) Clean dry cloth	BSK-TLST-001-12	KZ666	1 EA	
(2) Floor covering	PPP-001	KK999	1 pack	
(3) Specialist toolset	BSK-TLST-001	KZ666	1 EA	

Table TS-2 Consumables, materials and expendables

Name/Alternate name	Identification/Reference	MFR	Quantity	Remarks
(1) ACME sticky lube 52B	LL-007	KZ222	1 dl	
(2) AECMA Heavy duty Oil 1988	HD1988	B6865	1 dl	
(3) Degreasing agent	LL-004	KZ222	As required	
(4) General grease	LL-005	KZ222	As required	

Table TS-3 Spares

Name/Alternate name	Identification/Reference	MFR	Quantity	Remarks
N/A	N/A	N/A	N/A	N/A

S1000DBIKE-AAA-D00-00-01-00AA-341A-A

1. Fork testing

1. Climb on the bicycle.
2. Turn right and left several times.
3. Ride forward the bicycle.
4. Make sure that the wheels are stable.
5. Push in the fork.
6. Make sure that no oil or air is leaking out the fork.

End of S1000DBIKE-AAA-D00-00-01-00AA-341A-A

S1000DBIKE-AAA-DA5-20-00-00AA-251D-A

Preliminary requirements

Required conditions

Table TS-4 Required conditions

Actions/Condition	Data module/Technical publication
Rear wheel removed	S1000DBIKE-AAA-DA0-20-00-00AA-520A-A

7. level 1 Title 1.

A. level 2 Title A.

B. level 2 Step B.

(1) level 3 Step (1)

(a) level 4 Step (a)

1. level 5 Step 1.

a. level 6 Step a.

(1) level 7 Step (1)

(a) level 8 Step (a)

End of S1000DBIKE-AAA-DA5-20-00-00AA-251D-A

S1000DBIKE-AAA-DA4-10-00-00AA-241A-A

Preliminary requirements

Required conditions

Table TS-5 Required conditions

Actions/Condition	Data module/Technical publication
The bicycle chain is clean and dry	

Safety conditions

WARNING

Supply (1) (Wet lube (PN LL-007)) is a very dangerous substance. Do not get it onto your skin. Use it in a well ventilated area. If you swallow it seek immediate medical advice. If it gets into your eyes wash your eyes in clean water and seek medical advice.

APPLIC: Dry conditions

WARNING

Supply (2) (Dry lube (PN HD1988)) is a very dangerous substance. Do not get it onto your skin. Use it in a well ventilated area. If you swallow it seek immediate medical advice. If it gets into your eyes wash your eyes in clean water and seek medical advice.

8. Apply the penetrating lubricant into all the parts of the bike that move

A. Apply Supply (1) (Wet lube (PN LL-007)) to:

- derailleur pivots (refer to [Fig TS-1](#))
- derailleur tension (refer to [Fig TS-2](#))

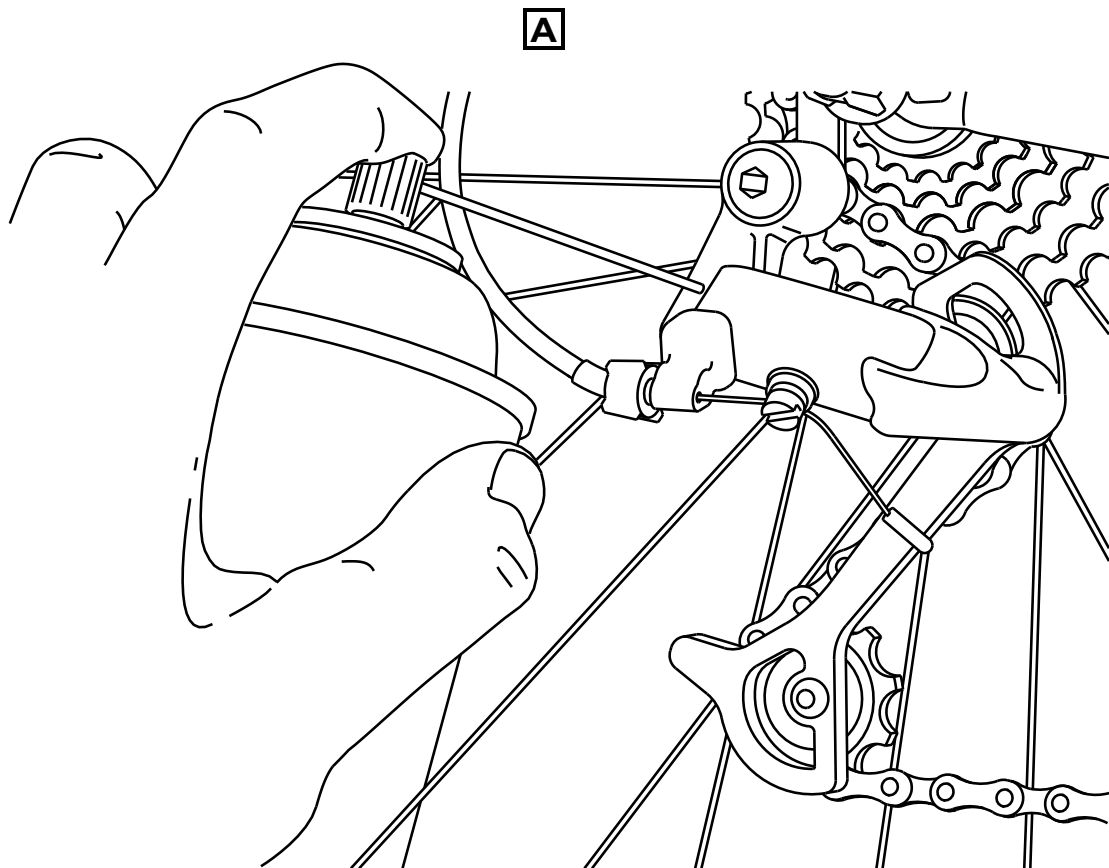
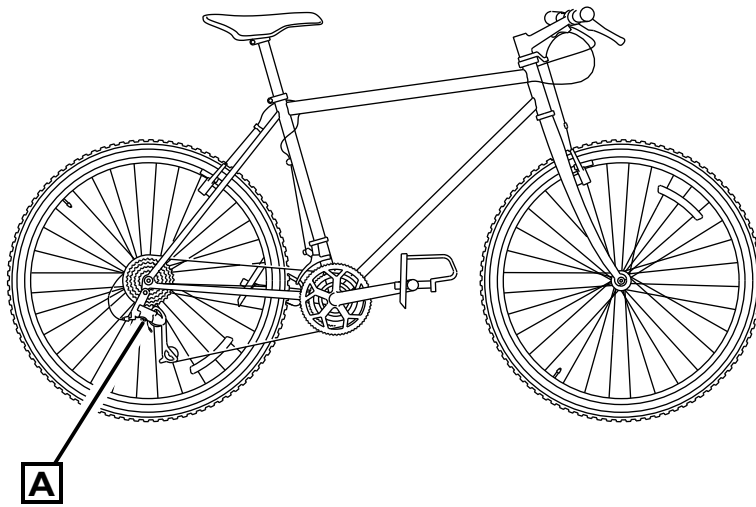

ICN-C0419-S1000D0398-001-01

Figure TS-1 Derailleur pivots

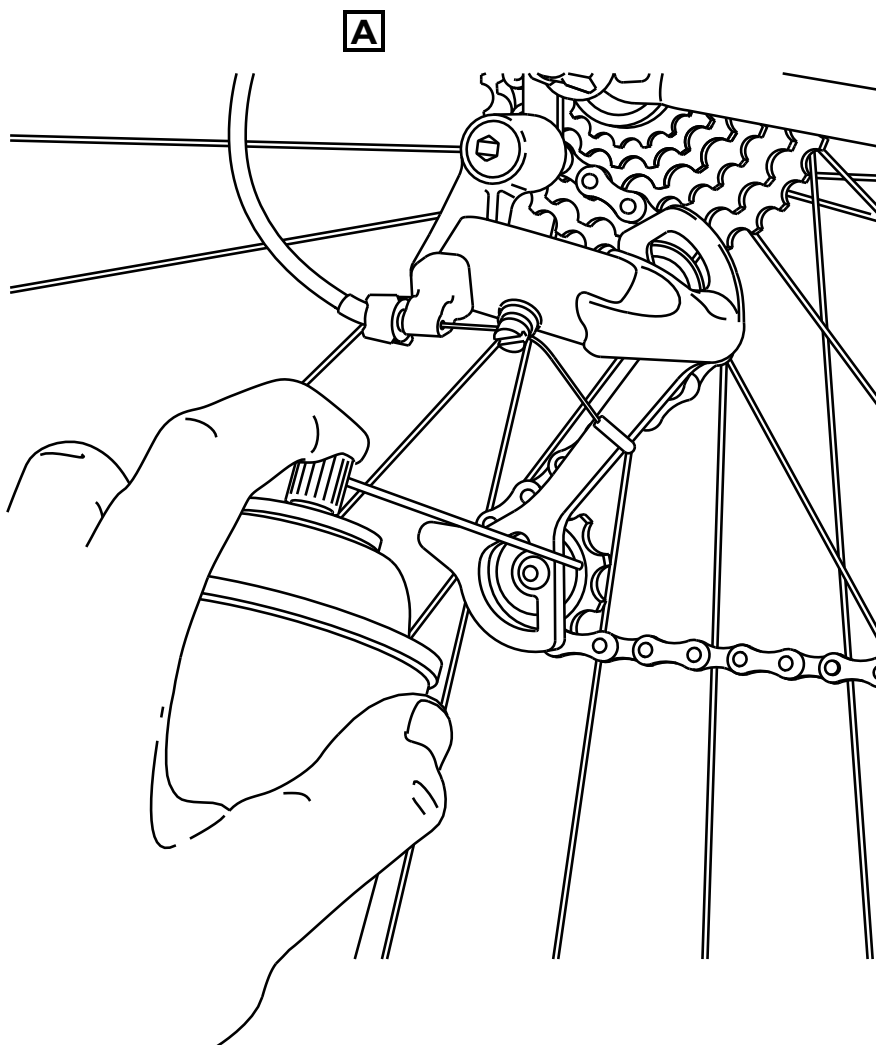
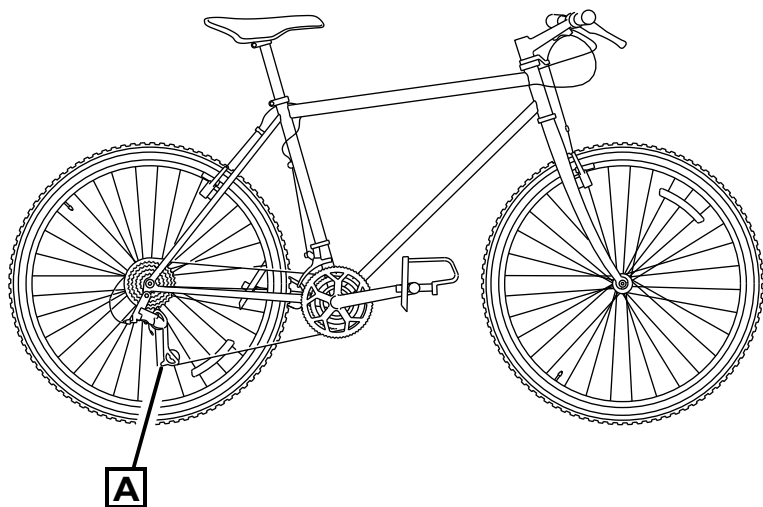

ICN-C0419-S1000D0399-001-01

Figure TS-2 Derailleur tension

B. Apply [Supply \(1\) \(Wet lube \(PN LL-007\)\)](#) to:

- brake lever pivots (refer to [Fig TS-3](#))

These brake lever pivots include:

- derailleur pivots
- derailleur tension
- guide wheels
- brake lever pivots
- control cables and where they go into their casings

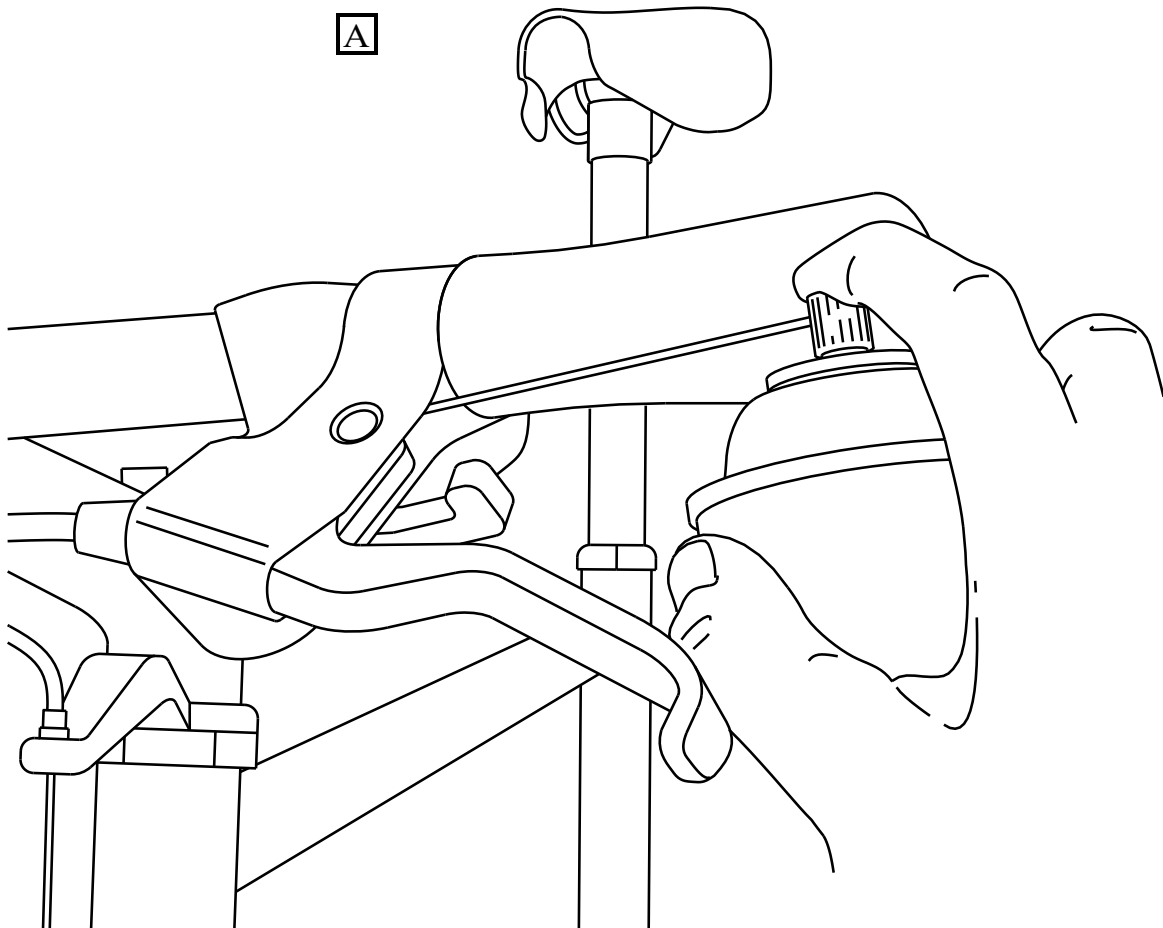
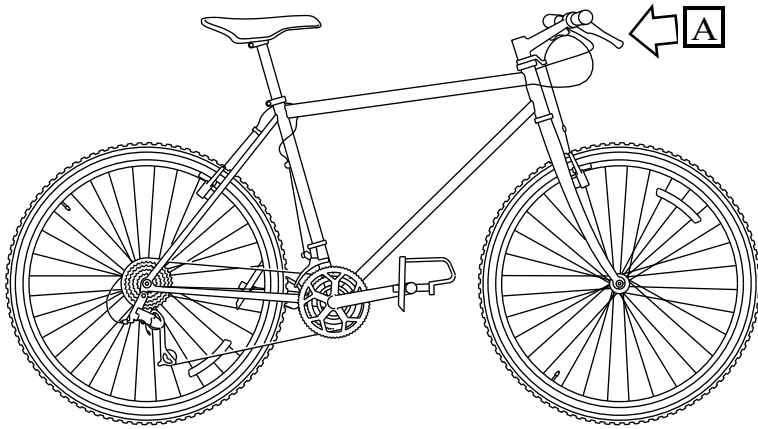

ICN-C0419-S1000D0383-001-01

Figure TS-3 Brake lever pivots

9. Lubricate the chain

- A. Make sure the chain is clean and dry.
- B. Put the [Tool \(2\) \(Floor covering \(PN PPP-001\)\)](#) on the floor below the chain.

APPLIC: Dry conditions

- C. Apply the [Supply \(2\) \(Dry lube \(PN HD1988\)\)](#) to each roller of the chain (refer to [Fig TS-4](#)) but only apply a small quantity.

APPLIC: Wet conditions

- D. Apply the [Supply \(1\) \(Wet lube \(PN LL-007\)\)](#) to each roller of the chain (refer to [Fig TS-4](#)) but only apply a small quantity.
- E. Hold the nozzle of the container above the front of the chain ring and slowly turn the cranks rearwards.

CAUTION

Do not get lubrication oil into the brake system. Oil in the break system can affect the efficiency of the bake system. Do not get oil onto the floor where it can easily get transferred onto the brake system.

- F. Let the lubricant soak into chain before you clean the unwanted lubricant from the chain.

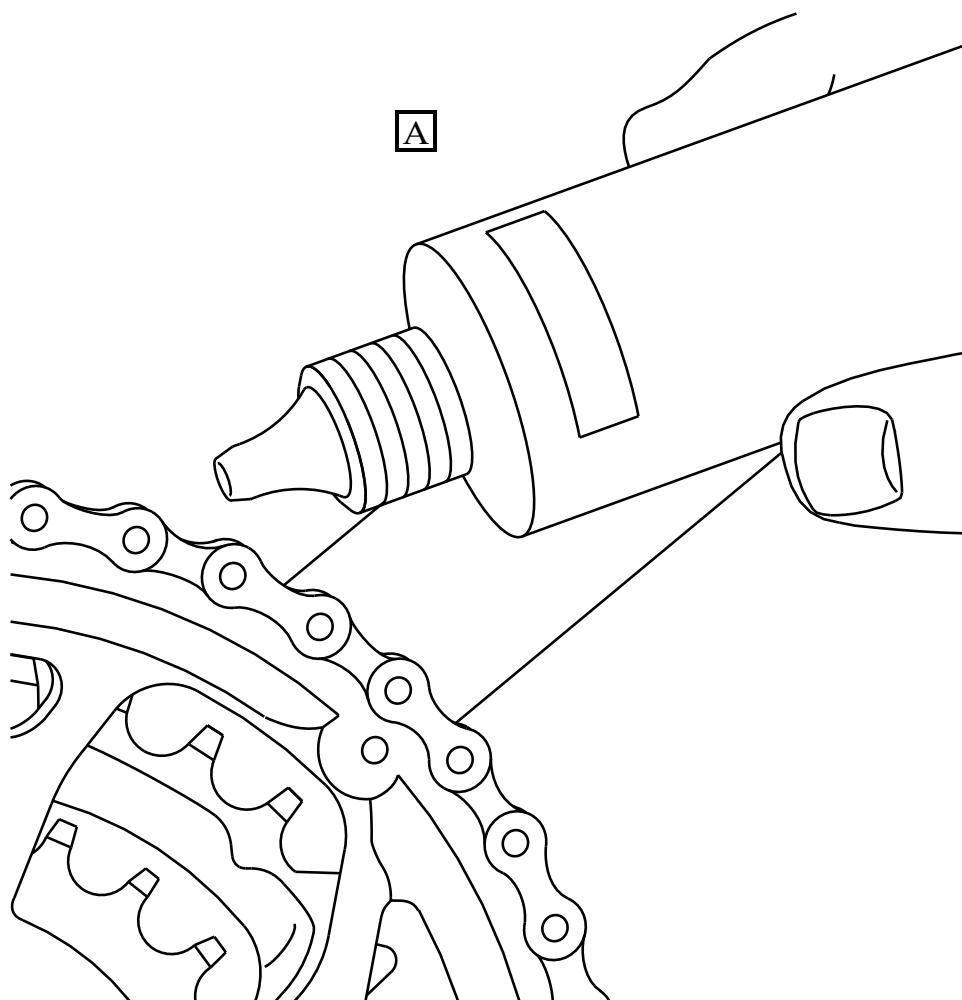
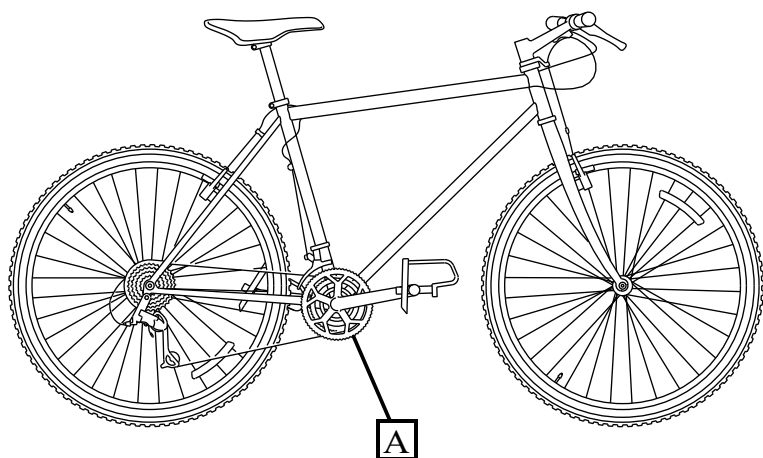

ICN-C0419-S1000D0395-001-01

Figure TS-4 Lubricate the chain

10. Check lubricated parts

- A. Do a check of the rear wheel rim and clean the unwanted lubricant if necessary.
- B. Do a check of the chain to make sure that each link is lubricated. If there are links that do not move easily or have become frozen, lubricate the chain again (refer to [Step 9.](#)).
- C. Do a check of the remaining lubricated parts and clean the unwanted lubricant with a [Tool \(1\)](#) ([Clean dry cloth \(PN BSK-TLST-001-12\)](#)).

*End of S1000DBIKE-AAA-DA4-10-00-00AA-241A-A
End of TASK SETS*

INTENTIONALLY BLANK

Servicing

Table SERVC-1 Support equipment

Name/Alternate name	Identification/Reference	MFR	Quantity	Remarks
(1) Chain cleaning fluid	LL-003	KZ222	As required	
(2) Chain cleaning tool	BSK-TLST-001-03	KZ666	1 EA	
(3) even shaped thingy	XYZ789-A	M1234	1	
(4) odd shaped thingy	XYZ789	M1234	1	
(5) Specialist toolset	BSK-TLST-001	KZ666	1 EA	
(6) Sponge	BSK-TLST-001-11	KZ666	1 EA	
(7) Stiff bristle brush	BSK-TLST-001-02	KZ666	1 EA	
(8) Tire pressure gauge	BSK-TLST-001-01		1	
(9) Torque wrench 1	1234	ZZZ	0.5 L	
(10) Torque wrench 2	BSK-TLST-001-01	KZ666	0.5 L	
(11) Water hose	BSK-TLST-001-09	KZ666	1 EA	test remark1 test remark2
- embed	123	ZZ	1	emb test remark1 emb test remark2

Table SERVC-2 Consumables, materials and expendables

Name/Alternate name	Identification/Reference	MFR	Quantity	Remarks
(1) ACME Middling Detergent 69	BSK-TLST-023-14	KZ666	1 L	
(2) ACME super 45 Agent	LL-004	AN777	1 L	test remark1 test remark2
- embedded Supplies	1234	AMB	1 EA	test remark1 test remark2
(3) BoeBus DeLux Detergent No.6	BSK-TLST-001-15	KZ666	1 L	
(4) Degreasing agent	LL-004	KZ222	As required	
(5) Floor covering	PPP-001	KK999	1 pack	
(6) General grease	LL-005	KZ222	As required	
(7) General lubricant	LL-001	KZ222	As required	
(8) glue	BSB-DUROFIX_FIXATIF_UW		0.5L	
(9) Lubricating grease 1	1234	ZZZ	0.5 L	

Name/Alternate name	Identification/Reference	MFR	Quantity	Remarks
(10) Lubricating grease 2	GRL-1234		1 L	
(11) magnetic tape	MB512	M1234	1	
(12) polytetraflouroethylene tape	Q2228	M1234	1	
(13) Rubbing alcohol	LL-002	KZ222	As required	

Table SERVC-3 Spares

Name/Alternate name	Identification/Reference	MFR	Quantity	Remarks
(1) fancy liner thingy	G5537	M1234	1	
(2) Gasket 1	1234	ZZZ	0.5 L	
(3) Gasket 2			0.5 L	
(4) Gasket 3	1234	ZZZ	0.5 L	
(5) light part	LRU1012 CSN Fig 01A Item 003A	K2777		
(6) Light system			1	
(7) spare 1	123	AMB	1	
(8) spare 2	123	AMB	1	test remark1 test remark2
- embedded spare	123	AMB	1	test remark1 test remark2
(9) spare 3	123	AMB	1	
(10) thermal sealent	YT6589	M1234	1	

S1000DBIKE-AAA-D00-00-00-00AA-258A-A

1. Common Information

- A. According to The International Bikers' Association (IBA) code of honor you are kindly requested to drive a properly maintained bicycle, which means the bike has to be regularly cleaned.

Preliminary requirements

Required conditions

Table SERVC-4 Required conditions

Actions/Condition	Data module/Technical publication
The bicycle is outdoors	

Safety conditions

WARNING

Do not get [Supply \(1\) \(Detergent A \(PN BSK-TLST-023-14\)\)](#) into your eyes. If it gets into your eyes, wash them immediately in clean warm water.

APPLIC: Mountain bicycle Brook trekker Mk9

WARNING

Do not get [Supply \(3\) \(Detergent C \(PN BSK-TLST-001-15\)\)](#) into your eyes. If it gets into your eyes, wash them immediately in clean warm water.

CAUTION

Do not use a [Tool \(11\) \(Water hose \(PN BSK-TLST-001-09\)\)](#) that has high pressure. A water hose that has high pressure can cause some parts to become loose or full of water.

CAUTION

Do not point the hose directly at the hub or at the bottom bracket bearings. This can cause damage to the parts.

APPLIC: Mountain bicycle Brook trekker Mk9

CAUTION

Apply [Supply \(3\) \(Detergent C \(PN BSK-TLST-001-15\)\)](#) in accordance with the instruction on the container. The substance may cause damage to the Bike paint if it is not applied correctly.

2. Cleaning the Bicycle

Clean the bicycle with water to remove all dirt. Refer to [Fig SERVC-1](#).

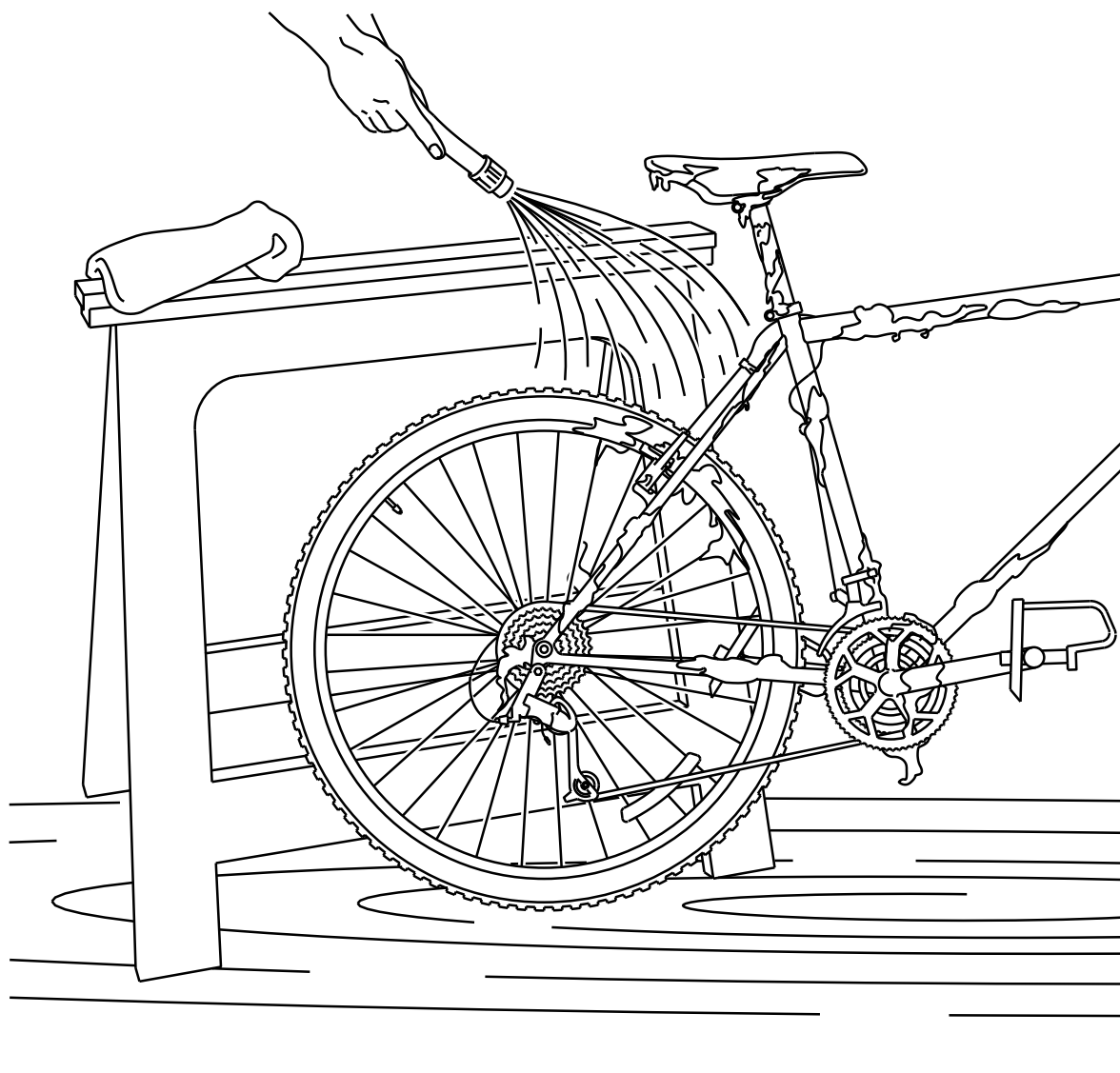

ICN-C0419-S1000D0359-001-01

Figure SERVC-1 Cleaning the bike

3. Use a [Tool \(7\) \(Stiff bristle brush \(PN BSK-TLST-001-02\)\)](#) to get access to areas that are not easy to clean. These are the shift levers, the knobby tires, and the brakes.
4. Clean the caked grime from the chain and the sprockets with a screwdriver that has a small blade.
5. Remove the grease from the freewheel assembly with the [Supply \(2\) \(Degreasing agent \(PN LL-004\)\)](#) as shown in [Fig SERVC-2](#).

Use a brush to remove the grease from these parts:

- sprockets
- guide and tension wheels of the derailleur
- chain ring teeth

Test link [Supply \(2\) \(embedded Supplies \(PN 1234\)\)](#)

Test link [Spare \(8\) \(embedded spare \(PN 123\)\)](#)

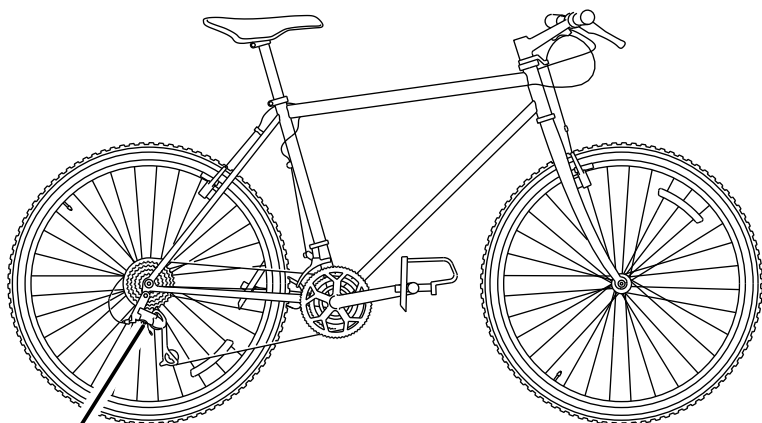

A

A

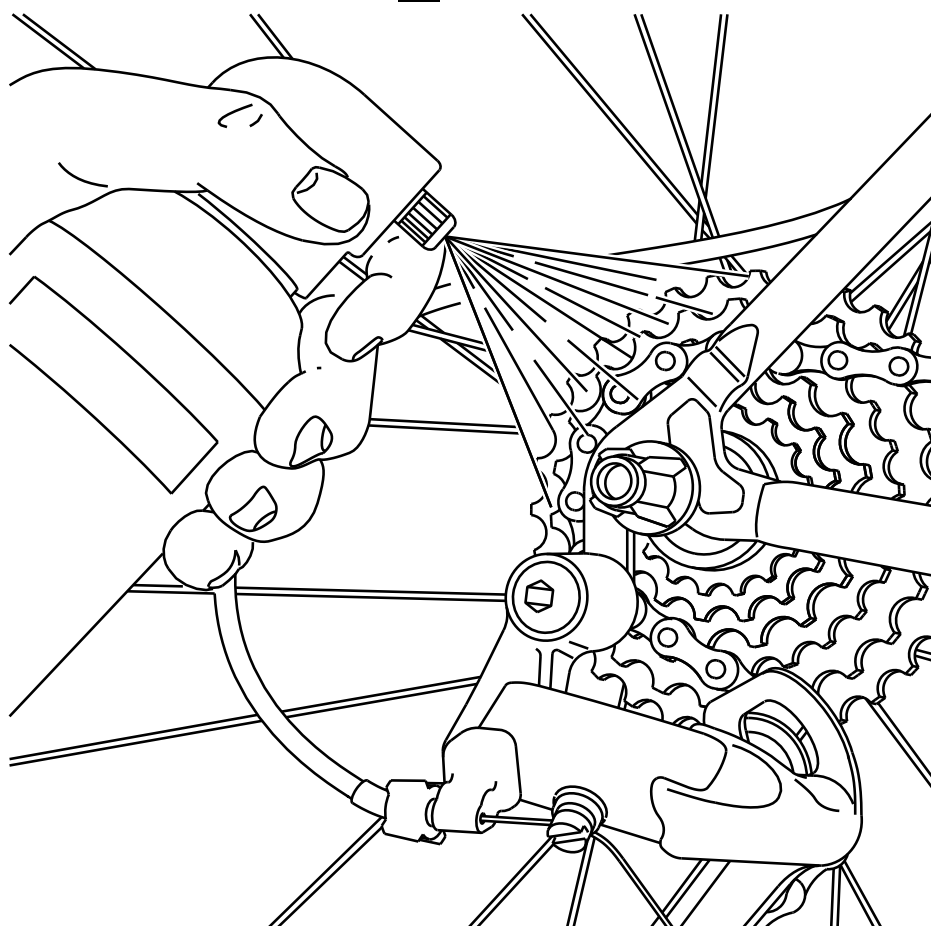

ICN-C0419-S1000D0400-001-01

Figure SERVC-2 Degreasing the freehub

6. Flush the sprockets, the derailleurs, the chain rings and the chain with water.

Note

If necessary, do the flush procedure again.

APPLIC: Mountain bicycle Mountain storm Mk1

7. Wash the Bike
 - A. Soak the [Tool \(6\) \(Sponge \(PN BSK-TLST-001-11\)\)](#) into [Supply \(1\) \(Detergent A \(PN BSK-TLST-023-14\)\)](#) and water.
 - B. Clean the bicycle with the soaked sponge.
 - C. Flush the bicycle and make sure that all [Supply \(1\) \(Detergent A \(PN BSK-TLST-023-14\)\)](#) is removed.
 - D. Move the bicycle up and down on its tires to remove all water.

APPLIC: Mountain bicycle Brook trekker Mk9

8. Wash the Bike
 - A. Soak the [Tool \(6\) \(Sponge \(PN BSK-TLST-001-11\)\)](#) into [Supply \(3\) \(Detergent C \(PN BSK-TLST-001-15\)\)](#) and water.
 - B. Clean the bicycle with the soaked sponge.
 - C. Soak the [Tool \(6\) \(Sponge \(PN BSK-TLST-001-11\)\)](#) into [Supply \(1\) \(Detergent A \(PN BSK-TLST-023-14\)\)](#) and water.
 - D. Fully clean the bicycle with the soaked sponge.
 - E. Flush the bicycle to make sure that all detergents are removed.
 - F. Move the bicycle up and down on its tires to remove all water.
9. Lubricate the bicycle. Refer to [S1000DBIKE-AAA-DA4-10-00-00AA-241A-A](#).
10. test change and rfu

Requirements after job completion

Required conditions

Table SERVC-5 Required conditions

Actions/Condition	Data module/Technical publication
Make sure the bicycle is dry	
Test reqcondexternalPub	(CMM code1234, titledfdfd)

End of S1000DBIKE-AAA-D00-00-00-00AA-258A-A

S1000DBIKE-AAA-DA5-20-00-00AA-251C-A

Preliminary requirements

Required conditions

Table SERVC-6 Required conditions

Actions/Condition	Data module/Technical publication
Rear wheel removed	S1000DBIKE-AAA-DA0-20-00-00AA-520A-A

11. Hub Cleaning

Remove the axle.

- A. Use the cone-wrench from the [Tool \(5\) \(Specialist toolset \(PN BSK-TLST-001\)\)](#) and remove the locknut from one side of the axle.
- B. Remove the washer and the cone from the axle.

CAUTION

Make sure you do not lose the bearings from the hub. Be prepared to catch the bearings if they fall out. Missing bearings can cause damage to the hub.

- C. Pull the axle out from the other side as shown in [Fig SERVC-3](#) .

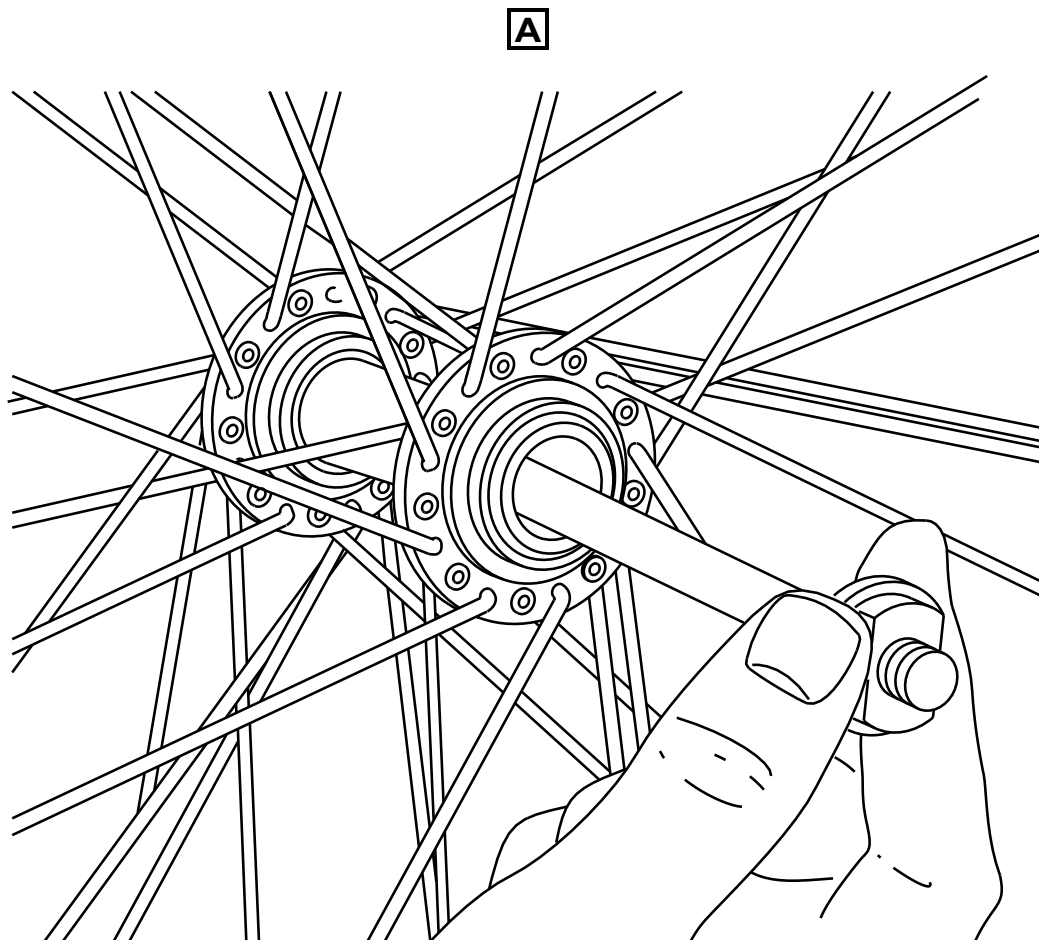
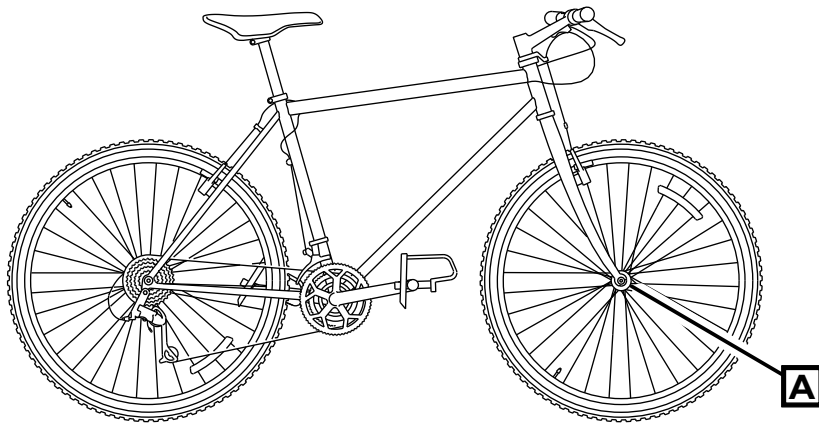

ICN-C0419-S1000D0401-001-01

Figure SERVC-3 Removing the axle

12. Remove the bearings.

- A. Use a small screwdriver from the [Tool \(5\) \(Specialist toolset \(PN BSK-TLST-001\)\)](#) and remove the bearings from their races.
- B. Make sure that each side of the hub has the same number of bearings.
- C. Use the [Supply \(4\) \(Degreasing agent \(PN LL-004\)\)](#) and clean all the parts of the hub.
- D. Do a check of the axle to make sure that it is straight.
- E. Examine the bearing contact area on the cones and the races in the hub for pitting and other signs of damage.
- F. Do a check of the ball bearings for signs of damage.
- G. Apply a large quantity of [Supply \(6\) \(General grease \(PN LL-005\)\)](#) on each hub race.

13. Assemble the hub.

- A. Install the ball bearings into the races and push them into the grease.
- B. Apply more grease on the tops of the bearings.
- C. Install the axle through the hub.
- D. Install the cone, the washer and the locknut on the other side of the axle.
- E. Use the cone-wrench from the specialist toolset and carefully tighten the locknut.

End of S1000DBIKE-AAA-DA5-20-00-00AA-251C-A

S1000DBIKE-AAA-DA1-10-00-00AA-251A-A

14. Brake pad cleaning

Do a visual inspection of the brakes as given in the pre-ride checks.

15. Clean the brake pads.

- A. Find each of the brake pads.
- B. Apply a thin layer of the [Supply \(13\) \(Rubbing alcohol \(PN LL-002\)\)](#) on each of the brake pads.
- C. Rub the surface until you have applied the [Supply \(13\) \(Rubbing alcohol \(PN LL-002\)\)](#) to the complete surface of the pad.
- D. Remove the unwanted alcohol.

End of S1000DBIKE-AAA-DA1-10-00-00AA-251A-A

S1000DBIKE-AAA-DA4-10-00-00AA-251B-A

16. Chain cleaning

Inspect the chain.

Do the inspection of the chain as given in the pre-ride checks.

17. Prepare the cleaning area.

- A. Put the [Supply \(5\) \(Floor covering \(PN PPP-001\)\)](#) on a satisfactory floor area.
- B. Put the bicycle on the floor covering.

18. Clean debris from the chain.

- A. Use the [Tool \(7\) \(Stiff bristle brush \(PN BSK-TLST-001-02\)\)](#) and loosen as much unwanted material as possible.
- B. Make sure that you remove all the unwanted material from the chain.

19. Clean the chain.
 - A. Open the [Tool \(2\) \(Chain cleaning tool \(PN BSK-TLST-001-03\)\)](#) and fill with the [Tool \(1\) \(Chain cleaning fluid \(PN LL-003\)\)](#).
 - B. Move the chain to the middle chainring and the middle sprocket at the rear.
 - C. Put the chain in the chain guides of the chain cleaning tool and lock the tool on the chain.
 - D. Hold the tool with the left hand and slowly turn the rearwards with the right hand.
 - E. Press the button on the cleaning tool to make sure that cleaning fluid flows until the tool is empty.
 - F. If necessary, remove the unwanted chain cleaning fluid.
20. Lubricate the chain.
 - A. Use the [Supply \(7\) \(General lubricant \(PN LL-001\)\)](#) and lubricate the chain.
 - B. Unlock and remove the cleaning tool.
 - C. If necessary, remove the unwanted lubricant.

Requirements after job completion

Required conditions

Table SERVC-7 Required conditions

Actions/Condition	Data module/Technical publication
Move the bicycle to its storage area and remove the floor covering.	

End of S1000DBIKE-AAA-DA4-10-00-00AA-251B-A

S1000DBIKE-AAA-D00-20-00-00AA-041A-A

21. Certe aliam quamcunque ambitionem inferiorem duxit re quam prae manibus habuit.
Itaque maxima ingenia proculdubio per singulas aetates vim passa sunt; dum viri captu et intellectu non vulgares, nihilo secius existimationi suae consulentes, temporis et multitudinis iudicio se submiserint.
Neque eum fugit quanta in solitudine versetur hoc experimentum, et quam durum et incredibile sit ad faciendam fidem.
22. In iis vero quae jam fiunt circa scientias, est vertigo quaedam et agitatio perpetua et circulus.
Atque apud populum plurimum vigent doctrinae aut contentiosae et pugnaces aut speciosae et inanes, quales videlicet assensum aut illaqueant aut demulcent.
 - A. Neque enim eorum quae inventa sunt nos poenitet.
 - (1) Atque apud populum plurimum vigent doctrinae aut contentiosae et pugnaces aut speciosae et inanes, quales videlicet assensum aut illaqueant aut demulcent.
 - (a) Nos certe, aeterno veritatis amore devicti, viarum incertis et arduis et solitudinibus nos commisimus; et divino auxilio freti et innixi, mentem nostram et contra opinionum violentias et quasi instructas acies, et contra proprias et internas haesitationes et scrupulos, et contra rerum caligines et nubes et undequaque volantes phantasias, sustinimus; ut tandem magis fida et segura indicia viventibus et posteris comparare possemus.
 1. Atque quam in inveniendis adhibemus humilitatem, eandem et in docendo sequuti sumus.

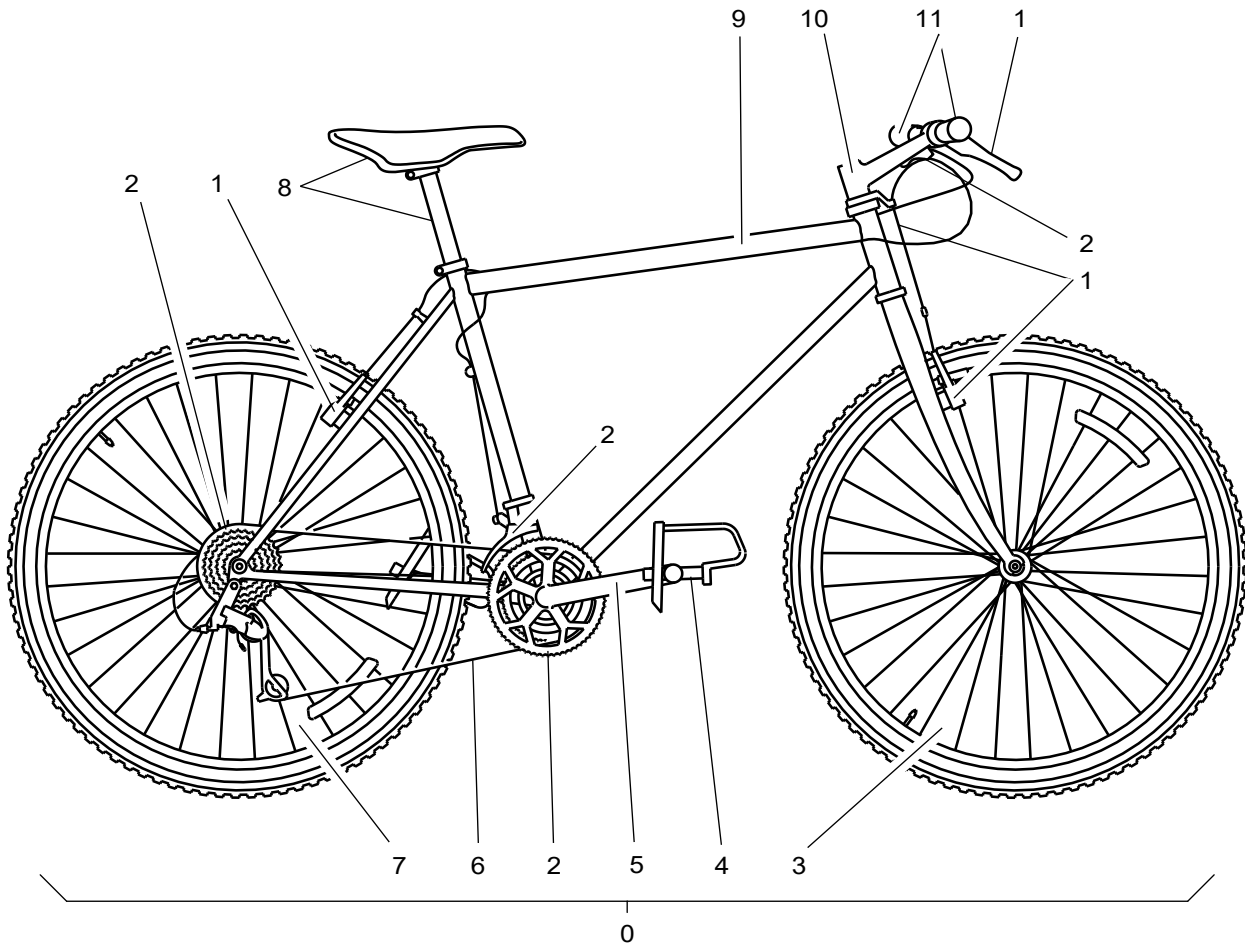

ICN-C0419-S1000D0360-001-01

Figure SERVC-4 sample graphic

Table SERVC-8 sample table

heading 1	heading 2	heading3
blah	blah	blah
blah		blah
		blah

23. Internal References

1. Refer to [Fig SERVC-4](#) [(161(A))]
2. Refer to [Table SERVC-8](#)[(161(B))]
3. Refer to [Para 22.](#)[(161(G))]
4. Refer to [Para 22.A.](#)[(161(H))]
5. Refer to [Para 22.A.\(1\)](#)[(161(I))]

6. Refer to [Para 22.A.\(1\)\(a\)](#)[161(J)]
7. Refer to [Para 22.A.\(1\)\(a\)1.](#)[161(K)]

End of S1000DBIKE-AAA-D00-20-00-00AA-041A-A

S1000DBIKE-AAA-D00-30-00-00AA-041A-A

24. Apply [Supply \(11\) \(mag tape \(PN MB512\)\)](#) local supply
 25. Use [Supply \(8\) \(glue\)](#) supply ref
 26. Use [Spare \(10\) \(gunk \(PN YT6589\)\)](#) local spare
 27. use [Spare \(6\) \(Light system\)](#) spare ref
 28. use [Tool \(3\) \(even thingy \(PN XYZ789-A\)\)](#) local equipment
 29. use [Tool \(8\) \(Tire pressure gauge \(PN BSK-TLST-001-01\)\)](#) tool ref
 30. Use [Spare \(5\) \(light part \(PN LRU1012\) CSN Fig 01A Item 003A\)](#) spare with CSN
 31. level one
 - A. level two
 - (1) level three
 - (a) level four
 1. level five
 - a. level six
 - (1) level seven
 - (a) level eight
32. go to [Step 31.](#)
33. go to [Step 31.A.](#)
34. go to [Step 31.A.\(1\)](#)
35. go to [Step 31.A.\(1\)\(a\)](#)
36. go to [Step 31.A.\(1\)\(a\)1.](#)
37. go to [Step 31.A.\(1\)\(a\)1.a.](#)
38. go to [Step 31.A.\(1\)\(a\)1.a.\(1\)](#)
39. go to [Step 31.A.\(1\)\(a\)1.a.\(1\)\(a\)](#)

End of S1000DBIKE-AAA-D00-30-00-00AA-041A-A
End of SERVICING

INTENTIONALLY BLANK

Examination, test, checks, and fault isolation

Table TEST-1 Support equipment

Name/Alternate name	Identification/Reference	MFR	Quantity	Remarks
(1) Specialist toolset	BSK-TLST-001	KZ666	1 EA	
(2) Sponge	BSK-TLST-001-11	KZ666	1 EA	
(3) Stiff bristle brush	BSK-TLST-001-02	KZ666	1 EA	
(4) Tire pressure gauge	BSK-TLST-001-01	KZ666	1 EA	
(5) Tire pressure gauge xx	BSK-TLST-001-01	KZ666	1 EA	
(6)	BSK-STS-001			
(7) Water hose	BSK-TLST-001-09	KZ666	1 EA	

Table TEST-2 Consumables, materials and expendables

Name/Alternate name	Identification/Reference	MFR	Quantity	Remarks
(1) ACME Middling Detergent 69	BSK-TLST-023-14	KZ666	1 L	
(2) ACME super 45 Agent	LL-004	KZ222	1 L	
(3) BoeBus DeLux Detergent No.6	BSK-TLST-001-15	KZ666	1 L	

Table TEST-3 Spares

Name/Alternate name	Identification/Reference	MFR	Quantity	Remarks
(1) Fork	Q7777 CSN D00-00-00 Fig 01 Item 006	M1234	1 EA	
- Fork	FK-TEL1002	KZ666	1 EA	
(2) Fork set	Q1213	M1234	1 EA	
- Fork set		KZ666	1 EA	
(3) Inner tube	IT-001	KT222	1 EA	

S1000DBIKE-AAA-D00-00-00-00AA-02BA-A

This is regulatory content. Cum illi pro comperto esset intellectum humanum sibi ipsi negotium facessere, neque auxiliis veris (quae in hominis potestate sunt) uti sobrie et commode; unde multiplex rerum ignoratio et ex ignoratione rerum detrimenta innumera: omni ope connitendum existimavit, si quo modo commercium istud Mentis et Rerum (cui vix aliquid in terris, aut saltem in terrenis, se ostendit simile) restitui posset in integrum, aut saltem in melius deduci.

End of S1000DBIKE-AAA-D00-00-00-00AA-02BA-A

S1000DBIKE-AAA-D00-00-00-00AA-258B-A

2. Common Information

- A. According to The International Bikers' Association (IBA) code of honor you are kindly requested to drive a properly maintained bicycle, which means the bike has to be regularly cleaned.

Preliminary requirements

Required conditions

Table TEST-4 Required conditions

Actions/Condition	Data module/Technical publication
The bicycle is outdoors	

Safety conditions

WARNING

Do not get [Supply \(1\) \(Detergent A \(PN BSK-TLST-023-14\)\)](#) into your eyes. If it gets into your eyes, wash them immediately in clean warm water.

APPLIC: Mountain bicycle Brook trekker Mk9

WARNING

Do not get [Supply \(3\) \(Detergent C \(PN BSK-TLST-001-15\)\)](#) into your eyes. If it gets into your eyes, wash them immediately in clean warm water.

CAUTION

Do not use a [Tool \(7\) \(Water hose \(PN BSK-TLST-001-09\)\)](#) that has high pressure. A water hose that has high pressure can cause some parts to become loose or full of water.

CAUTION

Do not point the hose directly at the hub or at the bottom bracket bearings. This can cause damage to the parts.

APPLIC: Mountain bicycle Brook trekker Mk9

CAUTION

Apply [Supply \(3\) \(Detergent C \(PN BSK-TLST-001-15\)\)](#) in accordance with the instruction on the container. The substance may cause damage to the Bike paint if it is not applied correctly.

3. Cleaning the bike

MKNXXX Clean the bicycle with water to remove all dirt. Refer to [Fig TEST-1](#).

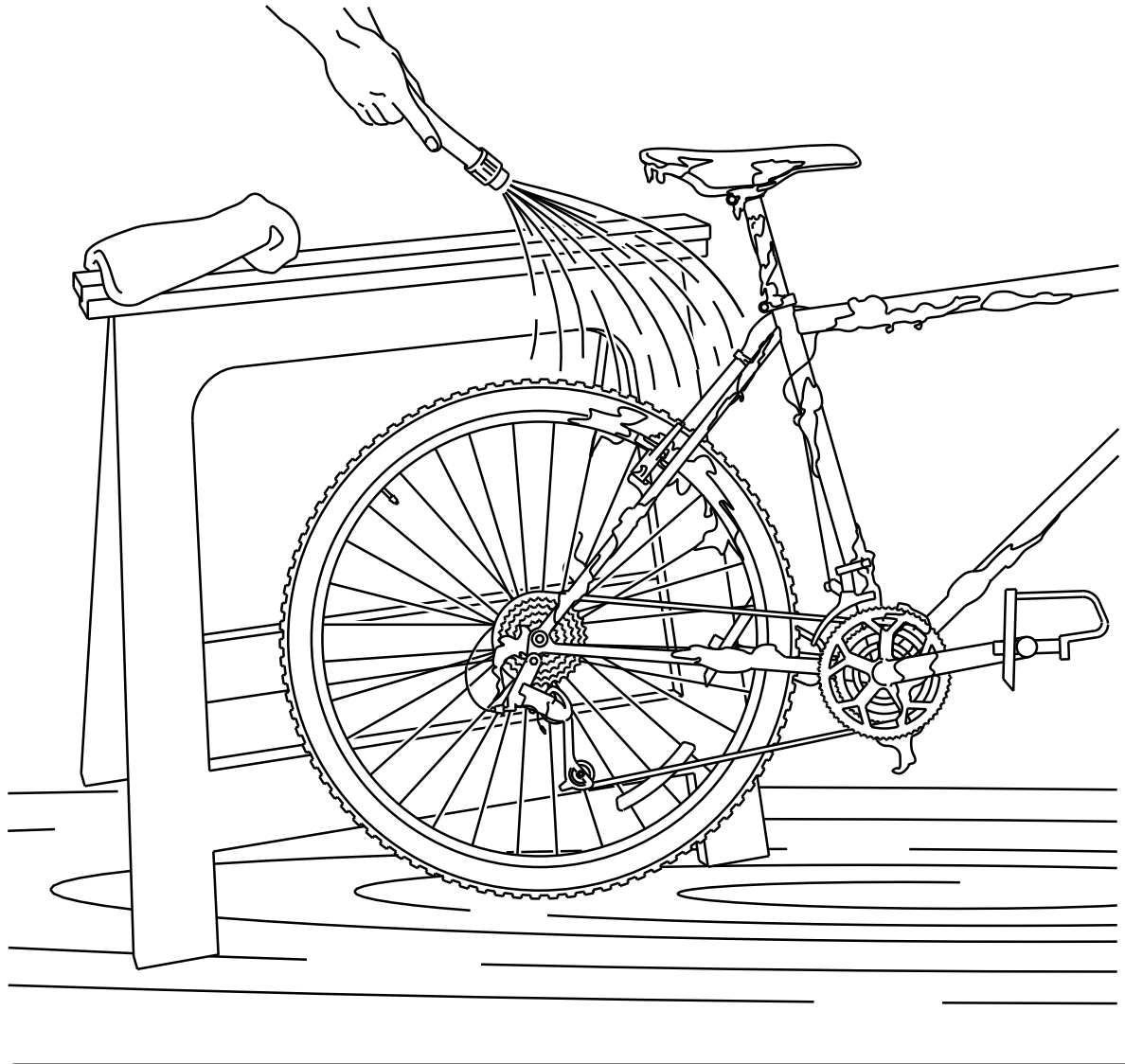

ICN-C0419-S1000D0359-001-01

MKNXXX Figure TEST-1 Cleaning the bike

EXAMINATION, TEST, CHECKS, AND FAULT ISOLATION

CTM23-10-10

2018-03-01

Page TEST-3

Copyright (C) 2025 by Contiem Ltd

4. Use a [Tool \(3\) \(Stiff bristle brush \(PN BSK-TLST-001-02\)\)](#) to get access to areas that are not easy to clean. These are the shift levers, the knobby tires, and the brakes.
5. Clean the caked grime from the chain and the sprockets with a screwdriver that has a small blade.
6. Remove the grease from the freewheel assembly with the [Supply \(2\) \(Degreasing agent \(PN LL-004\)\)](#) as shown in [Fig TEST-2](#).

Use a brush to remove the grease from these parts:

- sprockets
- guide and tension wheels of the derailleur
- chain ring teeth

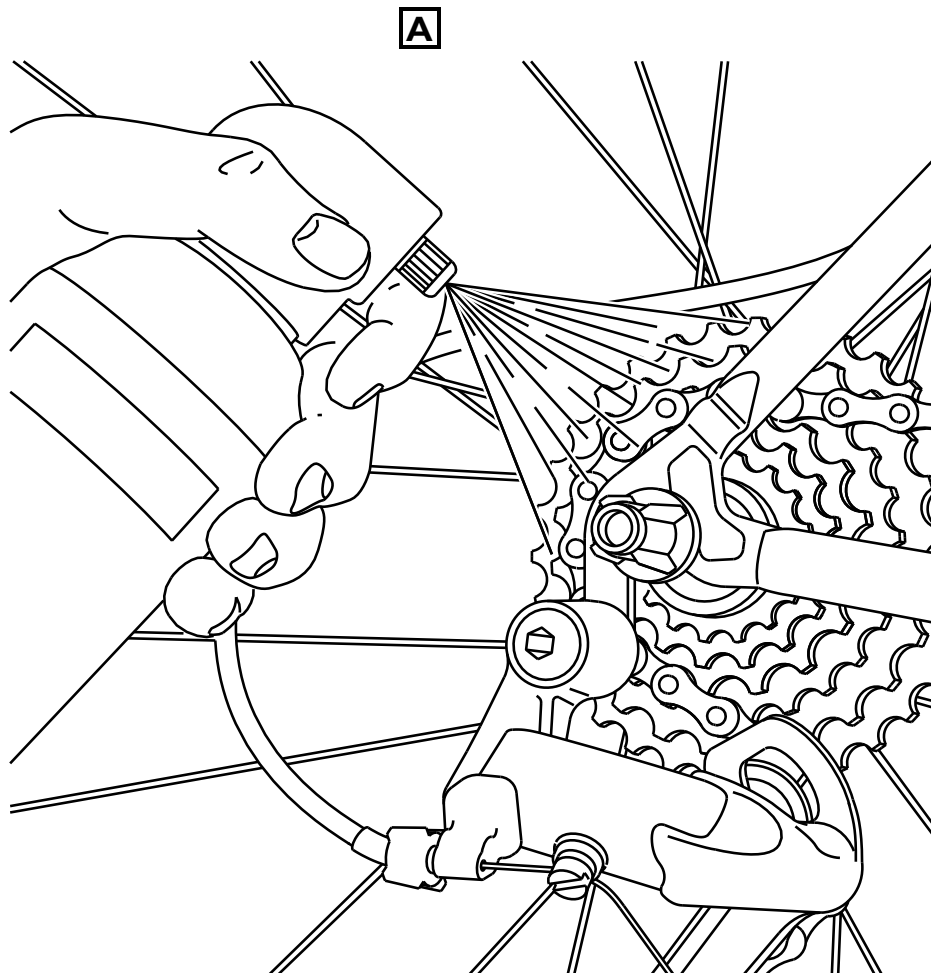
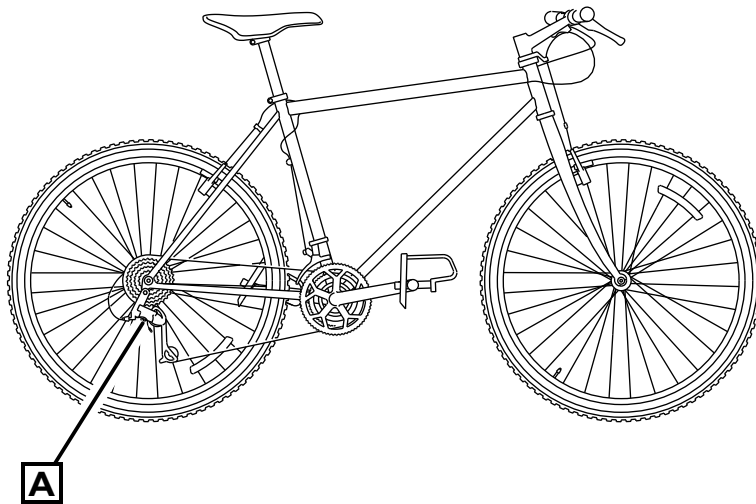

ICN-C0419-S1000D0400-001-01

Figure TEST-2 Degreasing the freehub

EXAMINATION, TEST, CHECKS, AND FAULT ISOLATION

CTM23-10-10

2018-03-01

Page TEST-5

7. Flush the sprockets, the derailleurs, the chain rings and the chain with water.

Note

If necessary, do the flush procedure again.

APPLIC: Mountain bicycle Mountain storm Mk1

8. [ALT] Wash the Bike
- Soak the [Tool \(2\) \(Sponge \(PN BSK-TLST-001-11\)\)](#) into [Supply \(1\) \(Detergent A \(PN BSK-TLST-023-14\)\)](#) and water.
 - Clean the bicycle with the soaked sponge.
 - Flush the bicycle and make sure that all [Supply \(1\) \(Detergent A \(PN BSK-TLST-023-14\)\)](#) is removed.
 - Move the bicycle up and down on its tires to remove all water.

APPLIC: Mountain bicycle Brook trekker Mk9

8. [ALT] Wash the Bike
- Soak the [Tool \(2\) \(Sponge \(PN BSK-TLST-001-11\)\)](#) into [Supply \(3\) \(Detergent C \(PN BSK-TLST-001-15\)\)](#) and water.
 - Clean the bicycle with the soaked sponge.
 - Soak the [Tool \(2\) \(Sponge \(PN BSK-TLST-001-11\)\)](#) into [Supply \(1\) \(Detergent A \(PN BSK-TLST-023-14\)\)](#) and water.
 - Fully clean the bicycle with the soaked sponge.
 - Flush the bicycle to make sure that all detergents are removed.
 - Move the bicycle up and down on its tires to remove all water.
9. Lubricate the bicycle. Refer to [S1000DBIKE-AAA-DA4-10-00-00AA-241A-A](#).

Requirements after job completion

Required conditions

Table TEST-5 Required conditions

Actions/Condition	Data module/Technical publication
Make sure the bicycle is dry	
<i>End of S1000DBIKE-AAA-D00-00-00-00AA-258B-A</i>	
<i>S1000DBIKE-AAA-DA0-10-10-00AA-921A-A</i>	

Preliminary requirements

Required conditions

Table TEST-6 Required conditions

Actions/Condition	Data module/Technical publication
The tire is removed.	S1000DBIKE-AAA-DA0-10-20-00AA-215A-A

Safety conditions

CAUTION

Be careful with sharp or hard tools. They can cause damage to the inner tube.

10. Inner tube installation

Remove the old inner-tube.

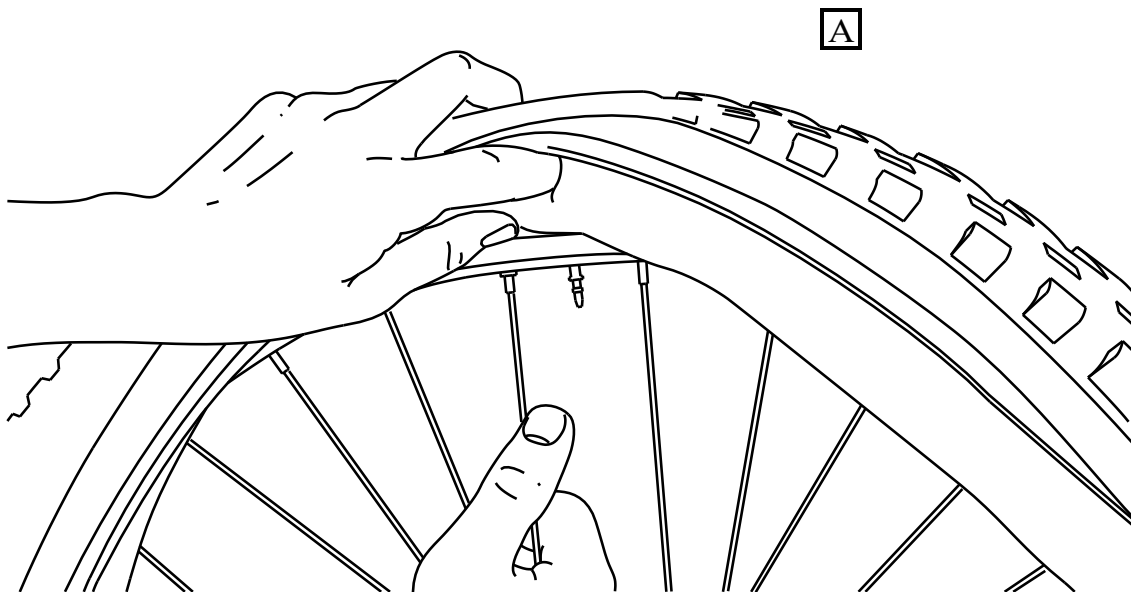
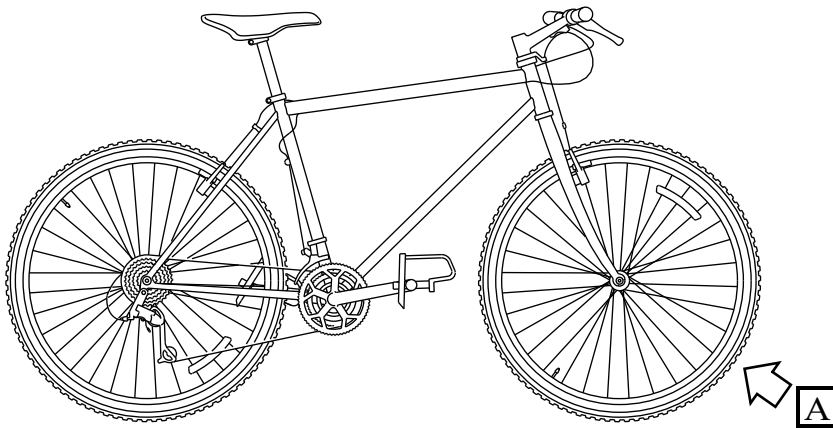

ICN-C0419-S1000D0369-001-01

Figure TEST-3 Removing the inner tube

11. Install the new [Spare \(3\) \(Inner tube \(PN IT-001\)\)](#).

Requirements after job completion

Required conditions

Table TEST-7 Required conditions

Actions/Condition	Data module/Technical publication
Replace the tire.	
Inflate the tire with air.	S1000DBIKE-AAA-DA0-10-20-00AA-215A-A

End of S1000DBIKE-AAA-DA0-10-10-00AA-921A-A

S1000DBIKE-AAA-DA0-10-20-00AA-362B-A

12. Check Tire Pressure

Locate the valve stem of tire.

13. Use the tire pressure gauge ([Tool \(4\) \(Tire pressure gauge \(PN BSK-TLST-001-01\)\)](#)) to check the tire pressure.
14. Tire pressure should between 2000 hPa to 2700 hPa.
- A. If tire pressure is less than 2000 hPa inflate tire. Refer to [S1000DBIKE-AAA-DA0-10-20-00AA-215A-A](#)
 - B. If the tire cannot maintain pressure or the tire pressure is greater than 2700 hPa replace the inner tube. Refer to [S1000DBIKE-AAA-DA0-10-10-00AA-921A-A](#)

End of S1000DBIKE-AAA-DA0-10-20-00AA-362B-A

S1000DBIKE-AAA-DA0-10-20-00AA-400A-A

Table TEST-8 Fault code NYCJD04

Fault code	Fault description
NYCJD04	Tire does not function correctly

15. Front wheel fault isolation

- A. Use the tire pressure gauge ([Tool \(5\) \(Tire pressure gauge xx \(PN BSK-TLST-001-01\)\)](#)) to do a check of the pressure
- B. What is the tire pressure reading?
 - (1) More than 2700 hPa: Go to [Step 15.C.](#)
 - (2) Between 100 hPa and 2700 hPa: Go to [Step 15.D.](#)
 - (3) Less than 100 hPa: Go to [Step 15.E.](#)
- C. Deflate the tire until the pressure is 2700 hPa
- D. Inflate the tire as given in [S1000DBIKE-AAA-DA0-10-20-00AA-215A-A](#)
- E. To do a check of the tire for damage
- F. Is there damage to the tire?
 - (1) Yes: Go to [Step 15.G.](#)
 - (2) No: Go to [Step 15.H.](#)
- G. Replace the tire (refer to [S1000DBIKE-AAA-DA0-10-20-00AA-921A-A](#))

H. Replace the inner-tube (refer to [S1000DBIKE-AAA-DA0-10-10-00AA-921A-A](#))

End of S1000DBIKE-AAA-DA0-10-20-00AA-400A-A

S1000DBIKE-AAA-DA1-00-00-00AA-341A-A

16. Brake testing

Put the bicycle in a vertical position.

17. Hold the handle bars and push the bicycle forwards.
18. Apply the brakes.
19. Make sure that the wheels lock and the bicycle stops.

End of S1000DBIKE-AAA-DA1-00-00-00AA-341A-A

S1000DLIGHTING-AAA-D00-00-00-00AA-341A-A

20. Lights testing

Set the lights to on.

21. Make sure that all the lights operate correctly.

End of S1000DLIGHTING-AAA-D00-00-00-00AA-341A-A

S1000DBIKE-AAA-D00-00-00-01AA-258A-A

Preliminary requirements

Required conditions

Table TEST-8 Required conditions

Actions/Condition	Data module/Technical publication
The bicycle is outdoors	

Safety conditions

WARNING

Do not get [Supply \(1\) \(Detergent A \(PN BSK-TLST-023-14\)\)](#) into your eyes. If it gets into your eyes, wash them immediately in clean warm water.

APPLIC: Mountain bicycle Brook trekker Mk9

WARNING

Do not get [Supply \(3\) \(Detergent C \(PN BSK-TLST-001-15\)\)](#) into your eyes. If it gets into your eyes, wash them immediately in clean warm water.

CAUTION

Do not use a [Tool \(7\) \(Water hose \(PN BSK-TLST-001-09\)\)](#) that has high pressure. A water hose that has high pressure can cause some parts to become loose or full of water.

CAUTION

Do not point the hose directly at the hub or at the bottom bracket bearings. This can cause damage to the parts.

APPLIC: Mountain bicycle Brook trekker Mk9

CAUTION

Apply [Supply \(3\) \(Detergent C \(PN BSK-TLST-001-15\)\)](#) in accordance with the instruction on the container. The substance may cause damage to the Bike paint if it is not applied correctly.

22. referring to the Bicycle

Refer to (figure) [Fig TEST-4](#).

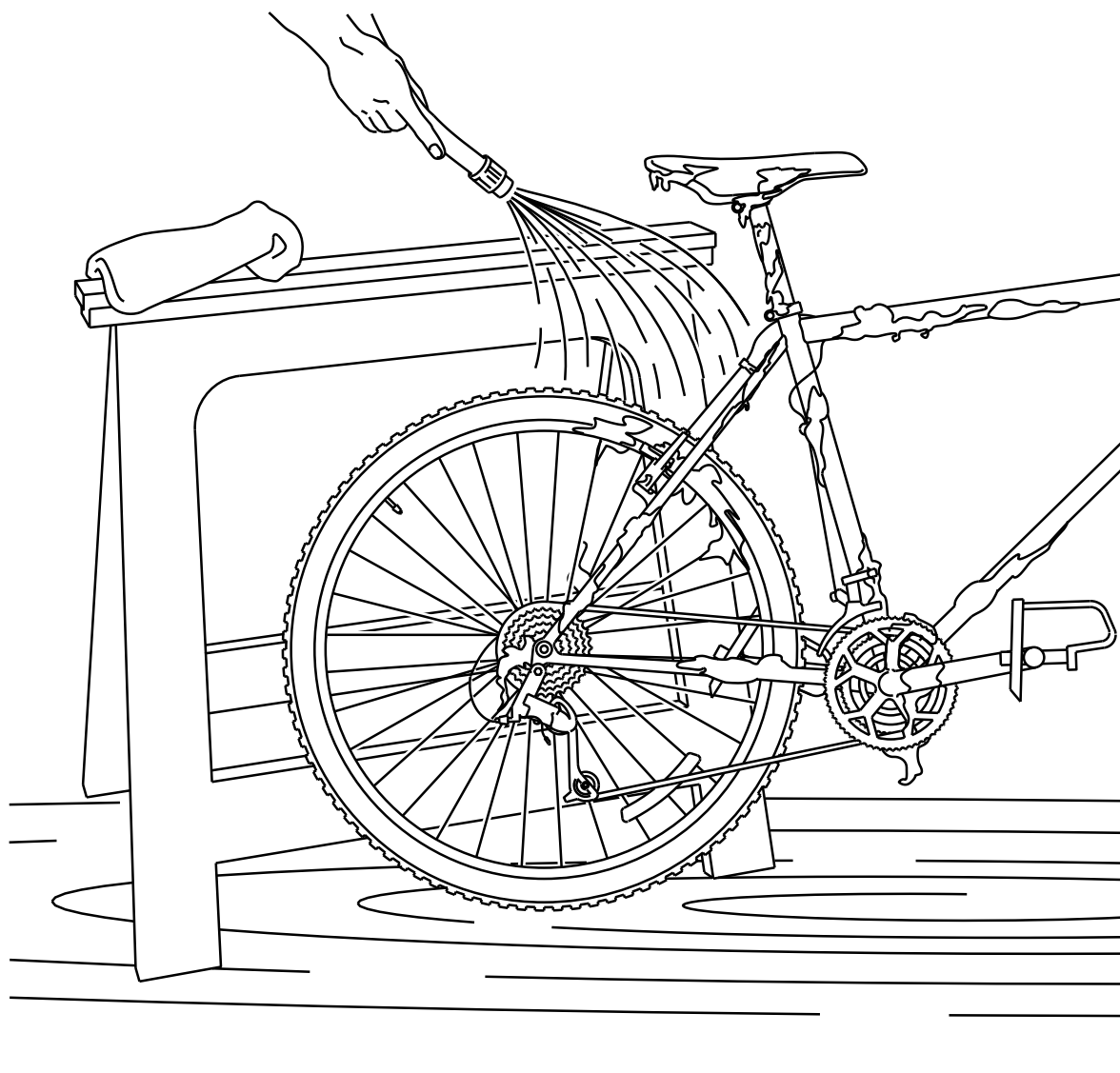

ICN-C0419-S1000D0359-001-01

Figure TEST-4 (Sheet 1 of 2) Cleaning the bike

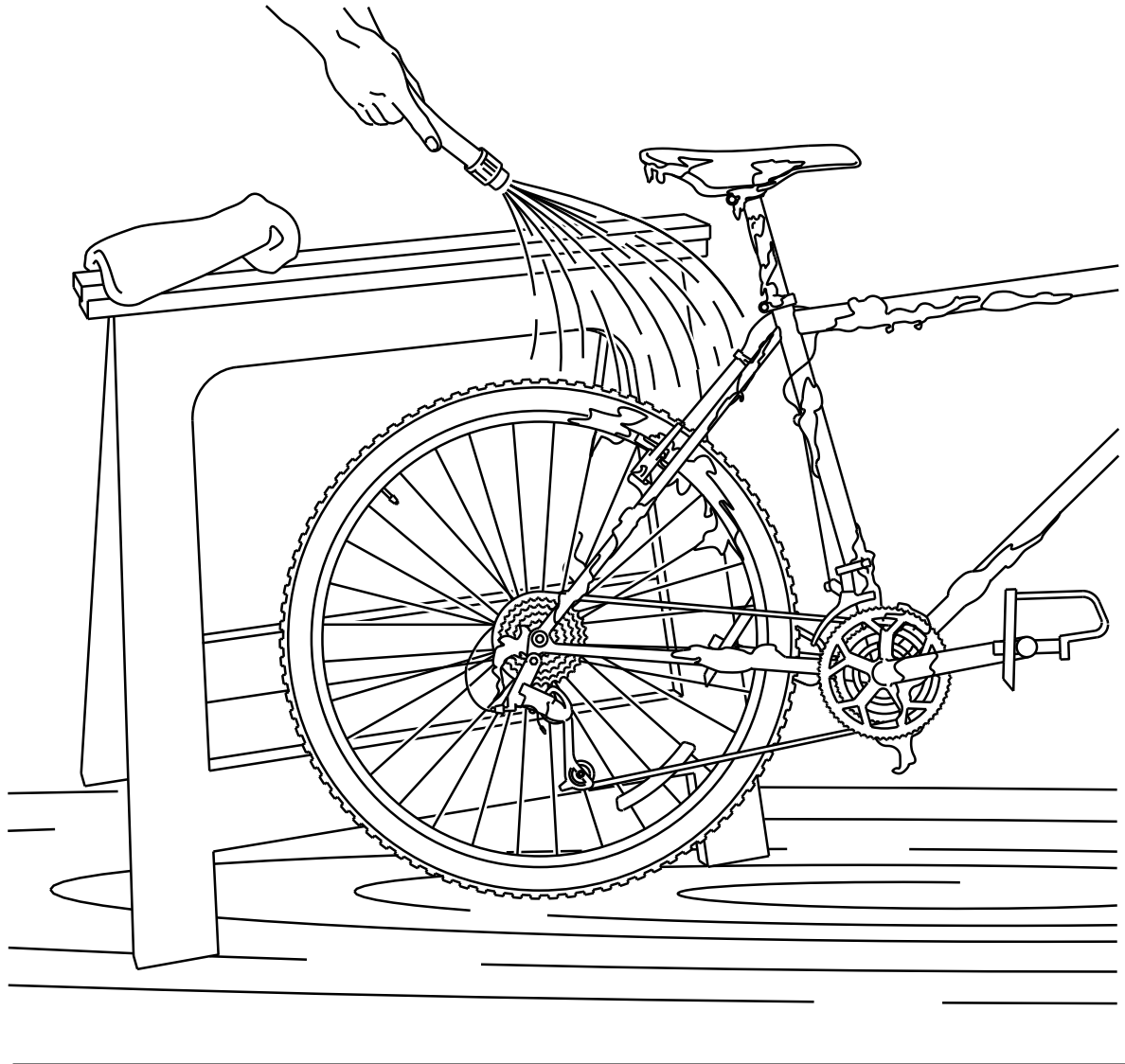

ICN-C0419-S1000D0359-001-01

Figure TEST-4 (Sheet 2 of 2) Cleaning the bike

23. Refer to (table)[Table TEST-9](#).
24. Refer to (supply)[Supply \(3\) \(Detergent C \(PN BSK-TLST-001-15\)\)](#).
25. Refer to (tool).[Tool \(6\) \(\(PN BSK-ST5-001\)\)](#)
26. Refer to (spare).[Spare \(2\) \(Fork set \(PN Q1213\)\)](#)
27. Refer to (spare-CSN).[Spare \(1\) \(Fork \(PN Q7777\) CSN D00-00-00 Fig 01 Item 006\)](#)
28. Refer to (sheet).[Fig TEST-4 \(Sheet 2 of 2\)](#)

Table TEST-9 Dummy table

heading 1	heading 2
cell 1-1	cell 1-2
cell 2-1	cell 2-2

Requirements after job completion

Required conditions

Table TEST-10 Required conditions

Actions/Condition	Data module/Technical publication
Make sure the bicycle is dry	

End of S1000DBIKE-AAA-D00-00-00-01AA-258A-A

S1000DBIKE-AAA-DA5-70-00-00AA-041A-A

29. external refs

1. Refer to [Shifters - Description of how it is made \(S1000DBIKE-AAA-DA3-00-00-00AA-041A-A\)](#)
2. Refer to (Brakes, BRAKE-B6865-EPWG1-00, Issue 2016-12-31, (BRAKE), (CAGE: B6865))
3. Refer to (ATA CMM 23-10-11, Power SupplyRevision 003)
4. Refer to [S1000DBIKE-AAA-DA3-00-00-00AA-041A-A](#)
5. Refer to [Fig FUNC-9](#)
6. conflicting info in Business rules — don't implement
7. Refer to IPD Figure [[IPD Figure D00-00-00-01A](#)]
8. Refer to IPD CSN [[Computer \(009A\)](#)]

End of S1000DBIKE-AAA-DA5-70-00-00AA-041A-A

End of EXAMINATION, TEST, CHECKS, AND FAULT ISOLATION

Disassemble

Table DIS-1 Support equipment

Name/Alternate name	Identification/Reference	MFR	Quantity	Remarks
(1) Set of Allen wrenches	BSK-TLST-001-13	KZ666	1 EA	
(2) Special Toolset			1 EA	
- Screwdriver	BSK-SCRDV-001		1 EA	embedded remarks
(3) Specialist toolset	BSK-TLST-001	KZ666	1 EA	
(4) Work stand	Stand-001	KZ555	1 EA	
(5) Work stand	Stand-001	Bikey	1 EA	

Table DIS-2 Consumables, materials and expendables

Name/Alternate name	Identification/Reference	MFR	Quantity	Remarks
(1) Thingy	Q12343	M1234	1	
(2) whatsit	Q56567	M1234	1	needed in cold weather only

Table DIS-3 Spares

Name/Alternate name	Identification/Reference	MFR	Quantity	Remarks
(1) Bulb	LIRUS-L1-11	KZ777	2 EA	
	CSN D00-00-00 Fig 01A Item 010A			
(2) Glass	LIRUS-G1-10	KZ777	1 EA	
	CSN D00-00-00 Fig 01A Item 022A			
(3) Glass	LIRUS-G1-10H	KZ777	1 EA	
	CSN D00-00-00 Fig 01A Item 023A			
- Glass	LIRUS-G1-10	KZ777	1 EA	
	CSN D00-00-00 Fig 01A Item 022A			
(4) Kit		KZ777	1 EA	
- Bulb ¹	LIRUS-B1-12F	KZ777	1 EA	
	CSN D00-00-00 Fig 01A Item 020A			
- Bulb ¹	LIRUS-B1-12R	KZ777	1 EA	
	CSN D00-00-00 Fig 01A Item 021A			

Note 1: Make sure that the new bulb is not cracked.

S1000DBIKE-AAA-D00-00-01-00AA-520A-A

1. Removing the fork

Remove the stem, refer to: [S1000DBIKE-AAA-DA2-10-00-00AA-520A-A](#)

2. Remove the headset, refer to: [S1000DBIKE-AAA-DA2-30-00-00AA-520A-A](#)
3. Push the fork downwards to remove it from the frame
4. Put the frame on the floor

End of S1000DBIKE-AAA-D00-00-01-00AA-520A-A

S1000DBIKE-AAA-DA0-20-00-00AA-520A-A

5. Rear wheel removal

Hold the rear of the bicycle.

6. Push the wheel forwards and down to disengage the chain from the sprocket.
7. Turn the wheel to the side and lift it away from the frame.
8. Put the frame on the floor.

End of S1000DBIKE-AAA-DA0-20-00-00AA-520A-A

S1000DBIKE-AAA-DA0-30-00-00AA-520A-A

9. Front wheel removal

Hold the front of the bicycle.

10. Use the ([Tool \(3\) \(Specialist toolset \(PN BSK-TLST-001\)\)](#)) to disengage the fork from the chainring by pushing the wheel forwards and down.
11. Lift the wheel away from the frame.
12. Put the frame on the floor.

End of S1000DBIKE-AAA-DA0-30-00-00AA-520A-A

S1000DBIKE-AAA-DA1-20-00-00AA-520A-A

13. Front brake removal

Hold the front of the bicycle.

14. Remove the front brake forwards.
15. Put the frame on the floor.

End of S1000DBIKE-AAA-DA1-20-00-00AA-520A-A

S1000DBIKE-AAA-DA2-10-00-00AA-520A-A

Preliminary requirements

Required conditions

Table DIS-4 Required conditions

Actions/Condition	Data module/Technical publication
Safety the bicycle in a bicycle stand and hold the front wheel off the ground	

Safety conditions

Note

It is not necessary to remove the handlebar when you remove the stem to get access to the headset.

16. Stem removal

Remove the handlebar [S1000DBIKE-AAA-DA2-20-00-00AA-520A-A](#)

17. Remove the stem.
 - A. Remove the bolt in the center of the stem cap.

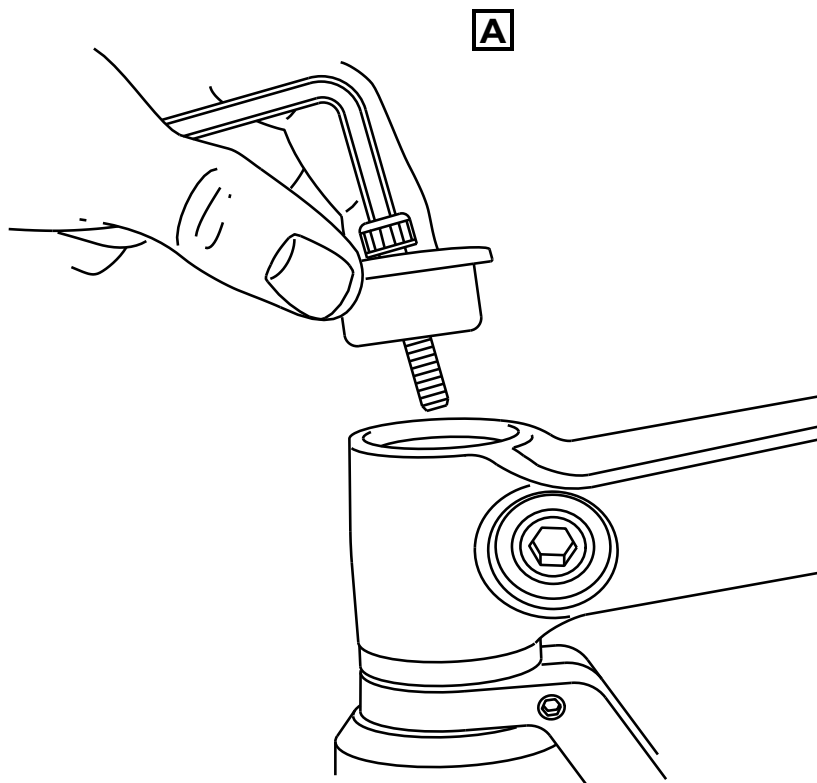
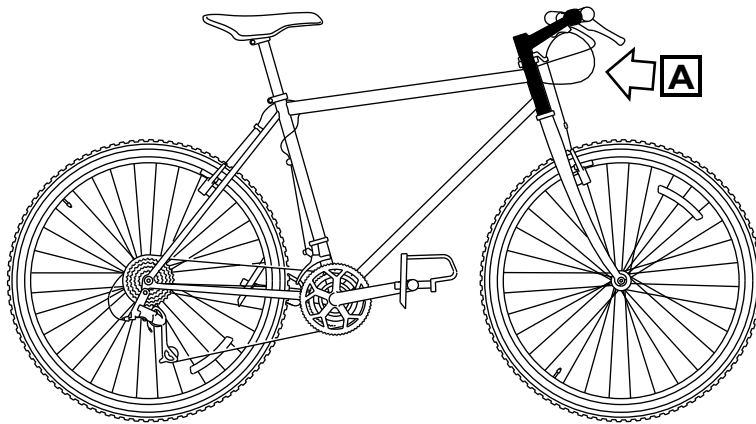

ICN-C0419-S1000D0387-001-01

Figure DIS-1 Remove the bolt

- B. Loosen the stem clam bolt with a [Tool \(1\) \(Set of Allen wrenches \(PN BSK-TLST-001-13\)\)](#).
- C. Remove the stem from the steerer tube.
- D. Note: It is not necessary to remove the handlebar if you remove the stem to get access to the headset.

End of S1000DBIKE-AAA-DA2-10-00-00AA-520A-A

S1000DBIKE-AAA-DA2-20-00-00AA-520A-A

Preliminary requirements

Required conditions

Table DIS-5 Required conditions

Actions/Condition	Data module/Technical publication
The bicycle is held safely on a work stand.	

Safety conditions

WARNING

Do not ride a bicycle with no grips on the handlebar. This can cause the hands of the rider to slip.

18. Remove the grips

- A. Put a long thin screwdriver below the grip and apply water between the grip and the handle bar.
- B. Turn the grip forwards and rearwards to loosen it and then pull it off the end of the handlebar.

19. Remove the brake and the shift levers from the handlebars

- A. Loosen the clamp screw (refer to [Fig DIS-2](#)) which is behind or below the brake lever (as shown).

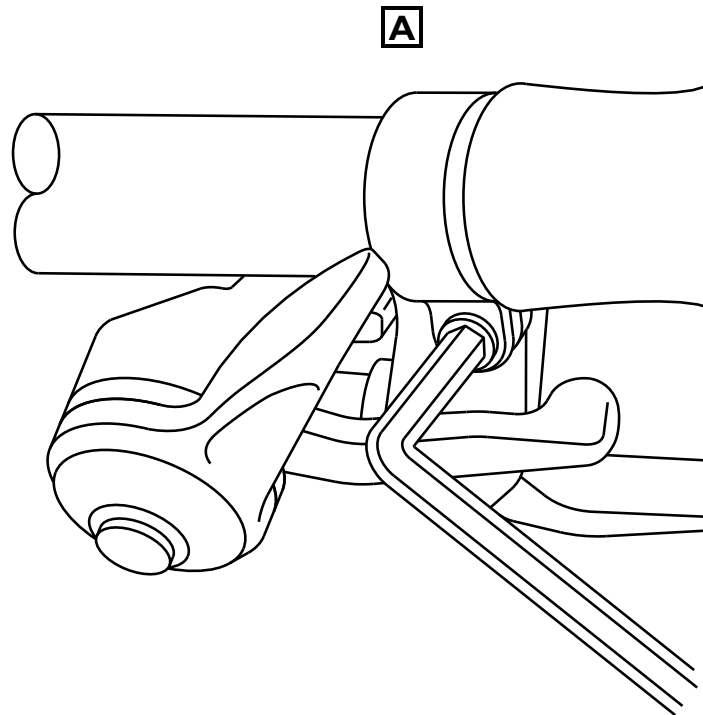
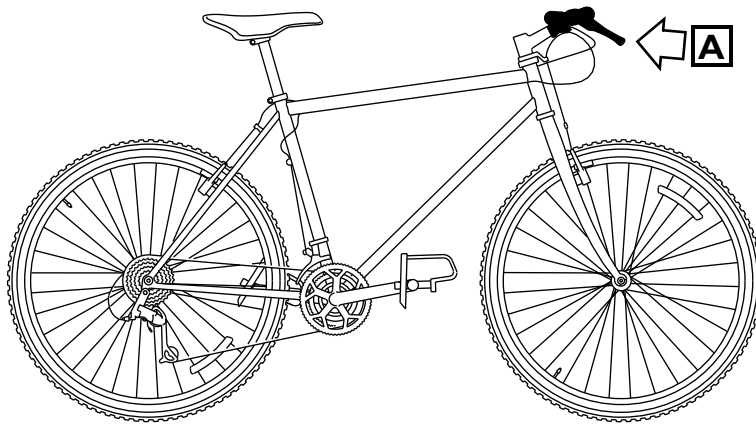

ICN-C0419-S1000D0389-001-01

Figure DIS-2 Loosen the clamp screw with the Allen wrench

- B. Remove the lever and the mount from the handlebar.
- C. Loosen the clamp bolt and remove the shifter from the handlebar.

20. Remove the handlebar

Use a [Tool \(1\) \(Set of Allen wrenches \(PN BSK-TLST-001-13\)\)](#) and loosen the clamp bolt (refer to [Fig DIS-3](#)). To remove, move the handlebar out of the stem.

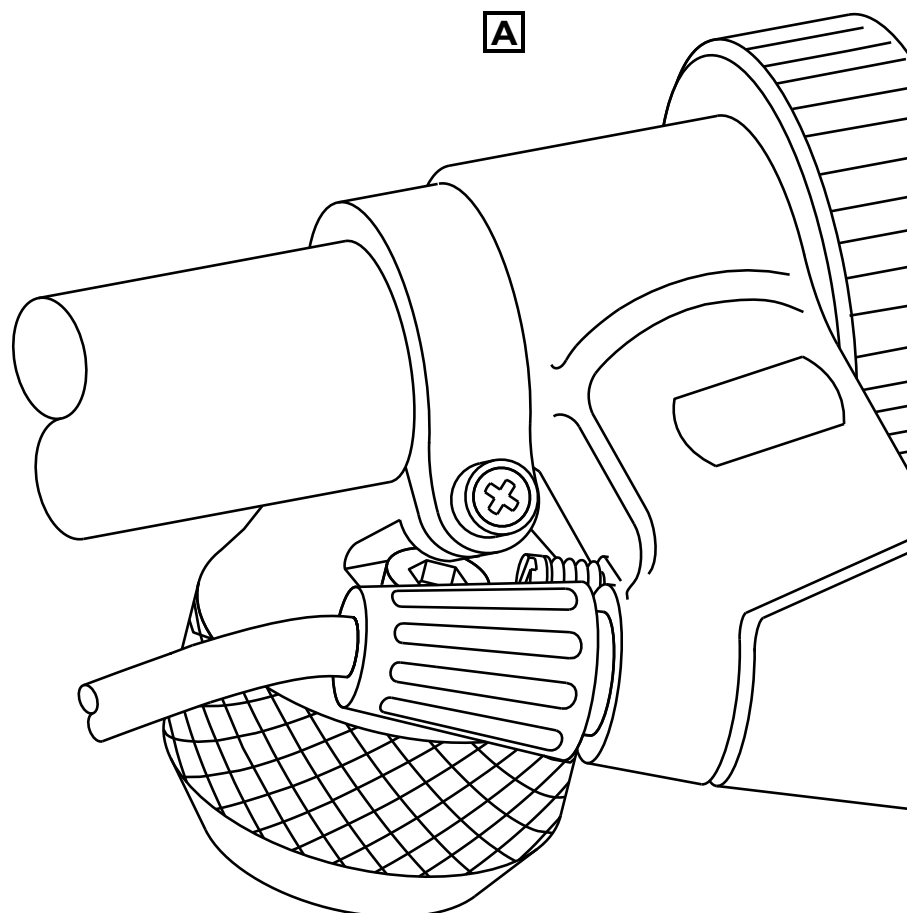
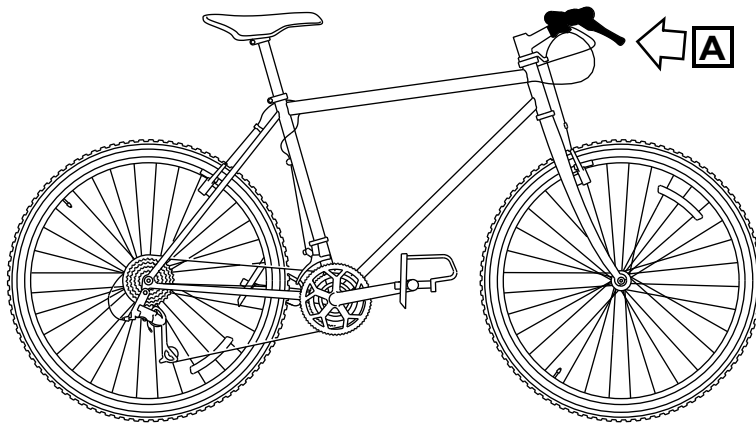

ICN-C0419-S1000D0388-001-01

Figure DIS-3 Loosen the clamp bolt

Preliminary requirements

Required conditions

Table DIS-6 Required conditions

Actions/Condition	Data module/Technical publication
The bicycle is safely held on a work stand	

Safety conditions

Note

It is not necessary to remove the handlebar for this procedure.

21. Headset removal

Remove the stem (refer to [S1000DBIKE-AAA-DA2-10-00-00AA-520A-A](#)).

22. Remove:

- the spacers
- the brake cable hangar
- the dust seals
- the conical expansion washer(s) from the steerer tube

23. Lift the upper bearing cup off (refer to [Fig DIS-4](#)) and then remove the fork from the frame.

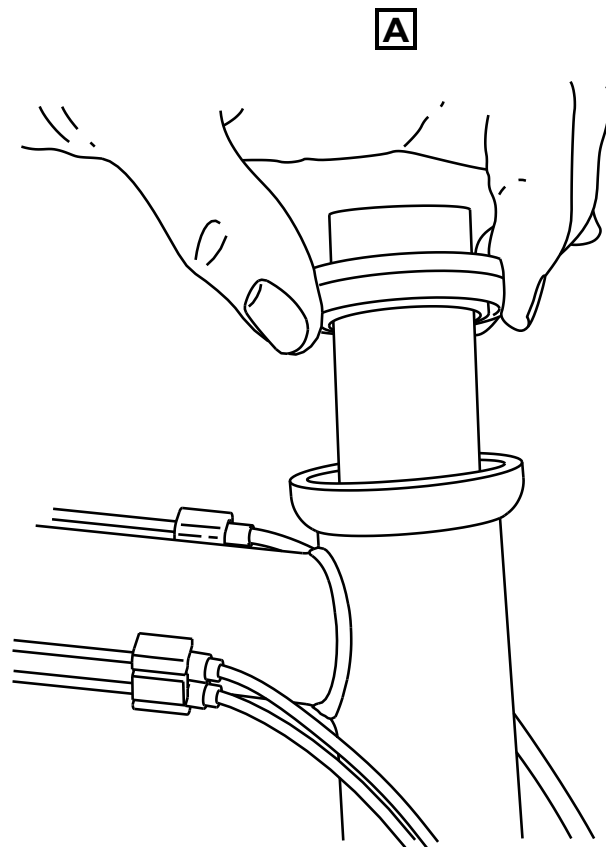
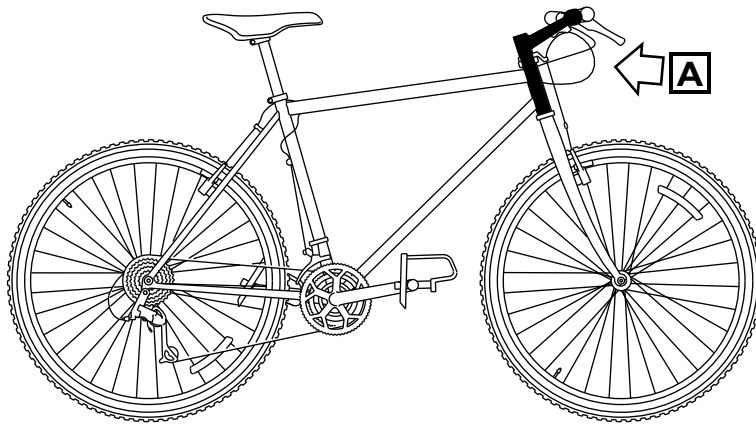

ICN-C0419-S1000D0390-001-01

Figure DIS-4 Lift the upper bearing cup

End of S1000DBIKE-AAA-DA2-30-00-00AA-520A-A

S1000DLIGHTING-AAA-D00-00-00-00AA-921A-A

WARNING



Make sure that the bulb is cool before you replace it.

CAUTION

Do not touch the glass of the bulb.

CAUTION

Make sure that the glass is clean before installing it on the light.

Preliminary requirements

Required conditions

Table DIS-7 Required conditions

Actions/Condition	Data module/Technical publication
Light set to off	
Light removed from bicycle	

Safety conditions

WARNING



Make sure that the bulb is cool before you replace it.

CAUTION

Do not touch the glass of the bulb.

CAUTION

Make sure that the glass is clean before installing it on the light.

24. Lighting replacement

Remove the glass [Spare \(2\) \(Glass \(PN LIRUS-G1-10\) CSN D00-00-00 Fig 01A Item 022A\)](#).

25. Remove the used front yellow bulb [Spare \(1\) \(Bulb \(PN LIRUS-L1-11\) CSN D00-00-00 Fig 01A Item 010A\)](#).

26. Discard the used bulb [Spare \(1\) \(Bulb \(PN LIRUS-L1-11\) CSN D00-00-00 Fig 01A Item 010A\)](#).

27. Remove the new white bulb [Spare \(4\) \(Bulb \(PN LIRUS-B1-12F\) CSN D00-00-00 Fig 01A Item 020A\)](#) from the kit [Spare \(4\) \(Kit\)](#).

28. Install the new white bulb [Spare \(4\) \(Bulb \(PN LIRUS-B1-12F\) CSN D00-00-00 Fig 01A Item 020A\)](#).

29. Install the glass [Spare \(2\) \(Glass \(PN LIRUS-G1-10\) CSN D00-00-00 Fig 01A Item 022A\)](#) on the light.

30. Attach the light fitting on the handlebar.

31. Apply the protective strip around the handlebar.

32. Install the washer on the screw.

33. Use the special screwdriver [Tool \(2\) \(Screwdriver \(PN BSK-SCRDV-001\)\)](#) from the toolset [Tool \(2\) \(Special Toolset\)](#) and tighten the screw into the hole at the bottom of the clamp. This safeties the clamp to the handlebar.
34. Remove the glass [Spare \(2\) \(Glass \(PN LIRUS-G1-10\) CSN D00-00-00 Fig 01A Item 022A\)](#).
35. Remove the used yellow rear bulb [Spare \(1\) \(Bulb \(PN LIRUS-L1-11\) CSN D00-00-00 Fig 01A Item 010A\)](#).
36. Discard the used bulb [Spare \(1\) \(Bulb \(PN LIRUS-L1-11\) CSN D00-00-00 Fig 01A Item 010A\)](#).
37. Remove the new white bulb [Spare \(4\) \(Bulb \(PN LIRUS-B1-12R\) CSN D00-00-00 Fig 01A Item 021A\)](#) from the kit [Spare \(4\) \(Kit\)](#).
38. Install the new white [Spare \(4\) \(Bulb \(PN LIRUS-B1-12R\) CSN D00-00-00 Fig 01A Item 021A\)](#).
39. Drill a 4mm hole in the middle of the glass [Spare \(3\) \(Glass \(PN LIRUS-G1-10\) CSN D00-00-00 Fig 01A Item 022A\)](#) in order to allow venting and heat evacuation when the light is switched on.
The glass with the hole may be ordered independently with the reference [Spare \(3\) \(Glass \(PN LIRUS-G1-10H\) CSN D00-00-00 Fig 01A Item 023A\)](#).
40. Install the glass with the hole [Spare \(3\) \(Glass \(PN LIRUS-G1-10H\) CSN D00-00-00 Fig 01A Item 023A\)](#) on the light.

Requirements after job completion

Required conditions

Table DIS-8 Required conditions

Actions/Condition	Data module/Technical publication
Switch the lights on if necessary.	

*End of S1000DLIGHTING-AAA-D00-00-00-00AA-921A-A
End of DISASSEMBLE*

INTENTIONALLY BLANK

Repair

Table REP-1 Support equipment

Name/Alternate name	Identification/Reference	MFR	Quantity	Remarks
(1) Foot pump	BSK-TLST-001-05	KZ666	1 EA	
(2) Marker pen	BSK-TLST-001-07	KZ666	1 EA	
(3) Saw tool set		M1234	1 EA	
- Saw tool set	BSK-STS-001		1 EA	
(4) Specialist toolset	BSK-TLST-001	KZ666	1 EA	
(5) Tire lever	BSK-TLST-001-04	KZ666	1 EA	
(6) Tire pressure gauge	BSK-TLST-001-01	KZ666	1 EA	
(7) Tube patch kit	BSK-TLST-001-07	KZ666	1 EA	

Table REP-2 Consumables, materials and expendables

Name/Alternate name	Identification/Reference	MFR	Quantity	Remarks
(1) General grease	LL-005	KZ222	As required	

Table REP-3 Spares

Name/Alternate name	Identification/Reference	MFR	Quantity	Remarks
(1) Fork	Q7777	M1234	1 EA	
- Fork	FK-TEL1002	KZ666	1 EA	
(2) Fork set	Q1213	M1234	1 EA	
- Fork set		KZ666	1 EA	
(3) Inner-tube	IT-001	KT222	1 EA	

S1000DBIKE-AAA-D00-00-00-00AA-663A-A

Preliminary requirements

Safety conditions

CAUTION

When you remove the rear wheel to repair a puncture, disconnect the brake arm from the chain stay.

1. Repair procedures

Remove the rear wheel. (Refer to [S1000DBIKE-AAA-DA0-20-00-00AA-520A-A](#))

WARNING

one line warning

2. Make sure that there is no air in the tube.

A. Loosen the cap on the valve stem.

- B. Push the valve stem core down to bleed all the air.
3. Use a [Tool \(5\) \(Tire lever \(PN BSK-TLST-001-04\)\)](#) to move the tire bead out of its seat. Lift the tire bead above the lip of the rim.

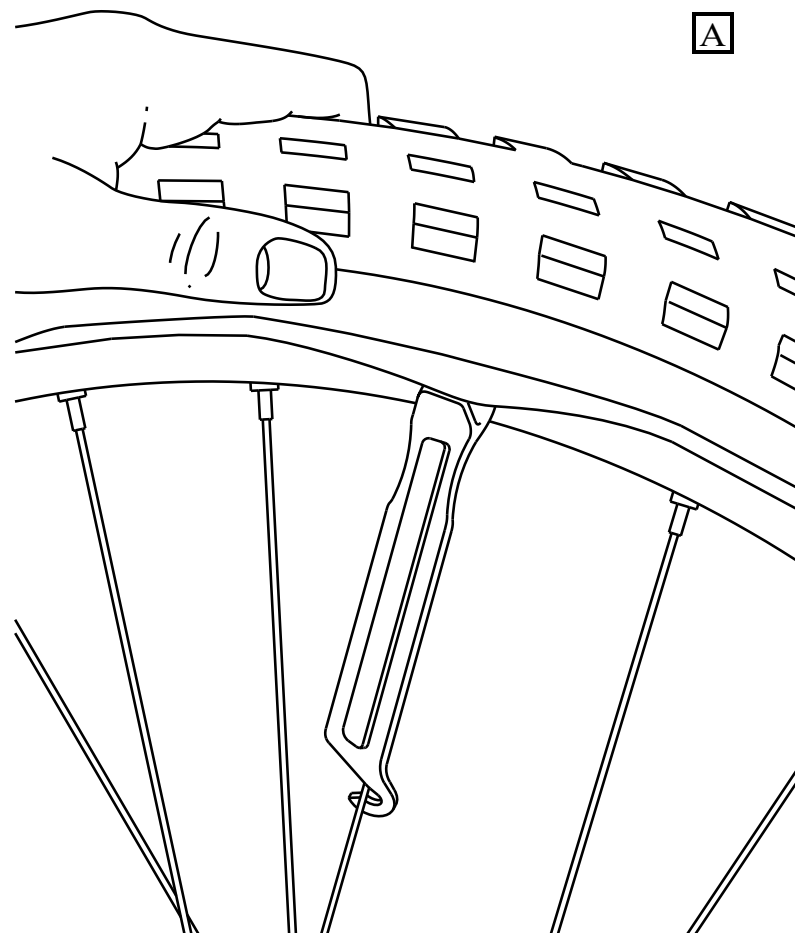
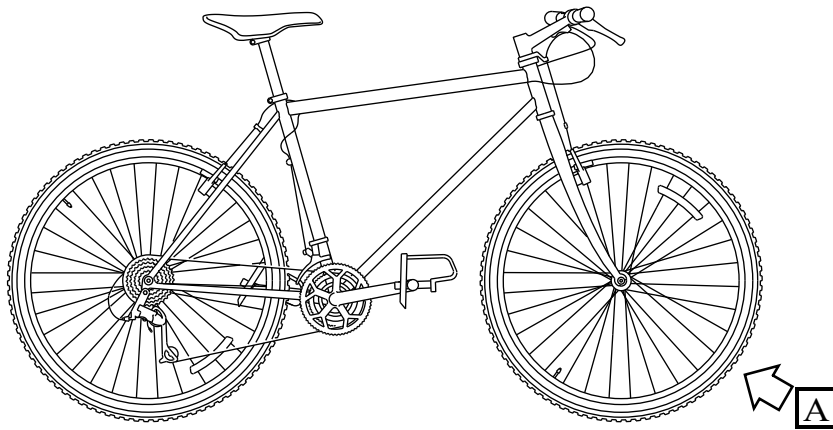

ICN-C0419-S1000D0368-001-01

Figure REP-1 Unseating the tire with a tire lever

4. Remove the tube.
5. Inflate (not fully) the tube with the [Tool \(1\) \(Foot pump \(PN BSK-TLST-001-05\)\)](#). Examine the tube for leaks.
6. If you find a leak, identify it with a circle made with a [Tool \(2\) \(Marker pen \(PN BSK-TLST-001-07\)\)](#).

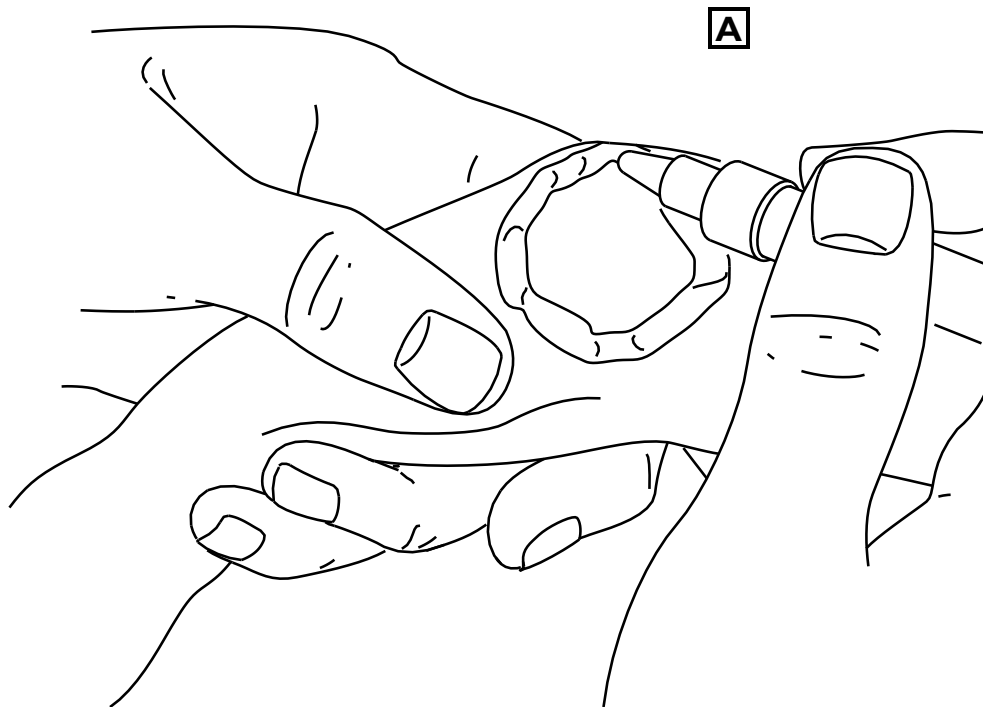
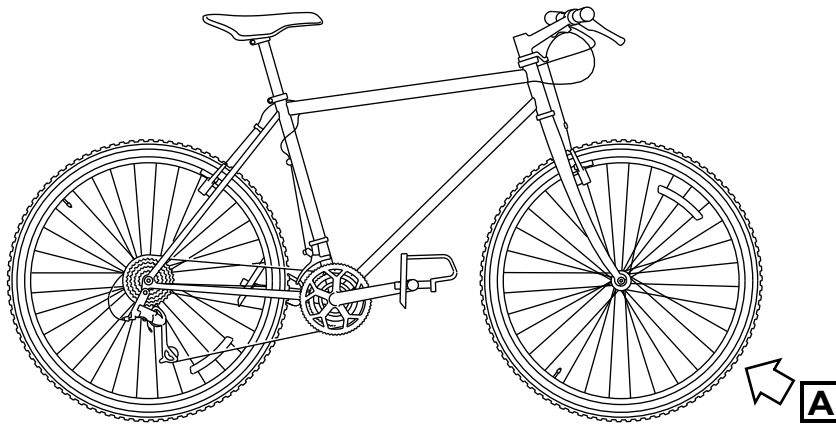

ICN-C0419-S1000D0375-001-01

Figure REP-2 Circle leak

7. Release most of the air.
8. Use a piece of sandpaper from the [Tool \(7\) \(Tube patch kit \(PN BSK-TLST-001-07\)\)](#) and make the area on and around the hole rough. This will help the patch bond correctly.

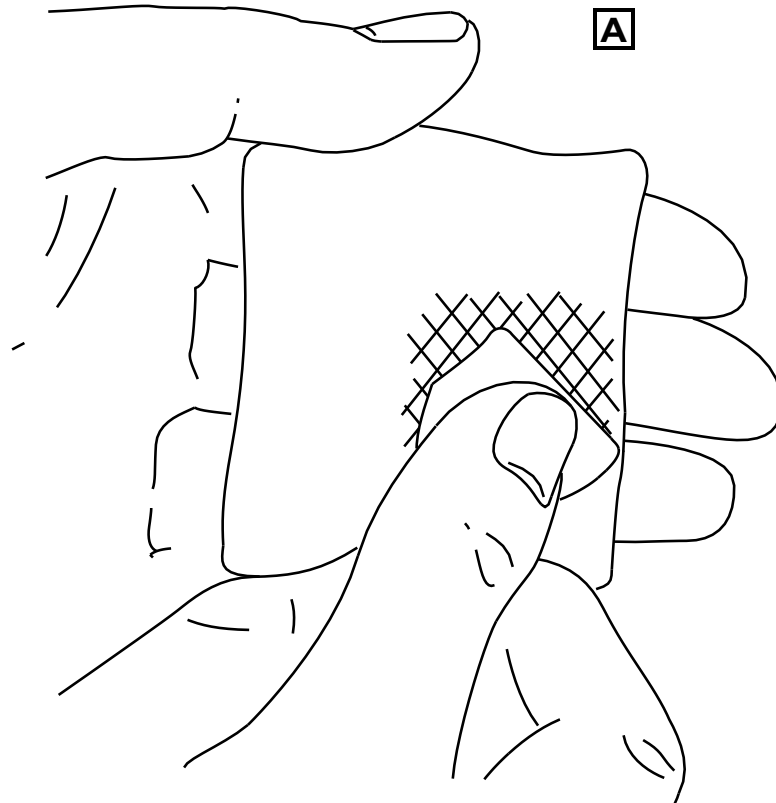
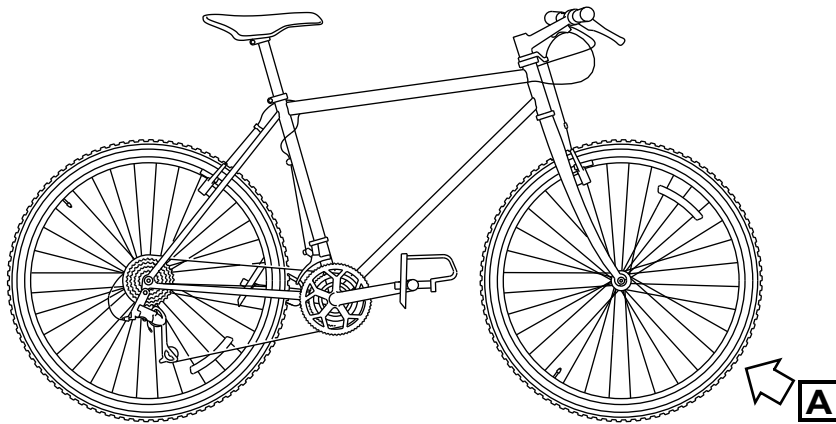

ICN-C0419-S1000D0376-001-01

Figure REP-3 Sanding the application area

9. Apply a thin layer of glue from the patch kit on and around the hole. Make sure that the area with the glue is larger than the patch.

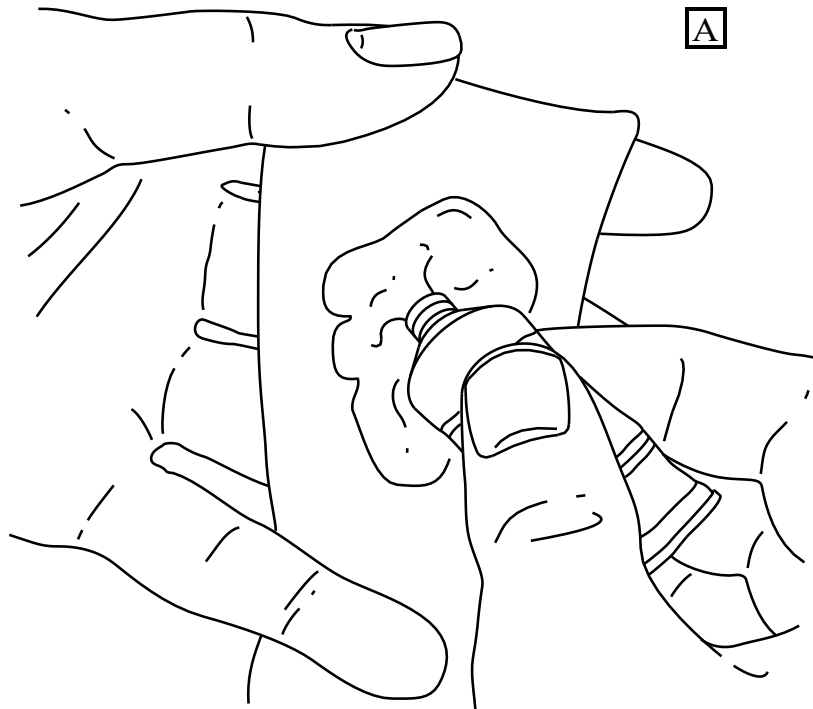
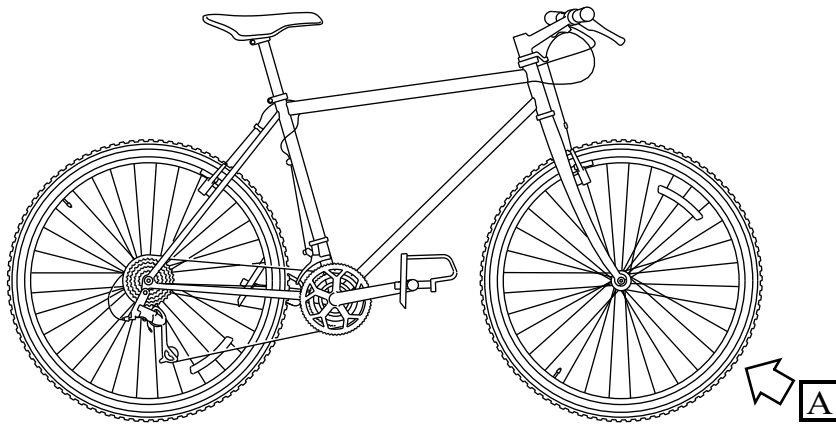

ICN-C0419-S1000D0377-001-01

Figure REP-4 Apply glue to application area

10. Let the glue dry for five minutes until it becomes tacky and dim.
11. Remove the rear foil from the patch (that is a part of the patch kit) and push the patch in its position.
12. Push with your thumbs from the center of the patch to the outer part of the applied area.

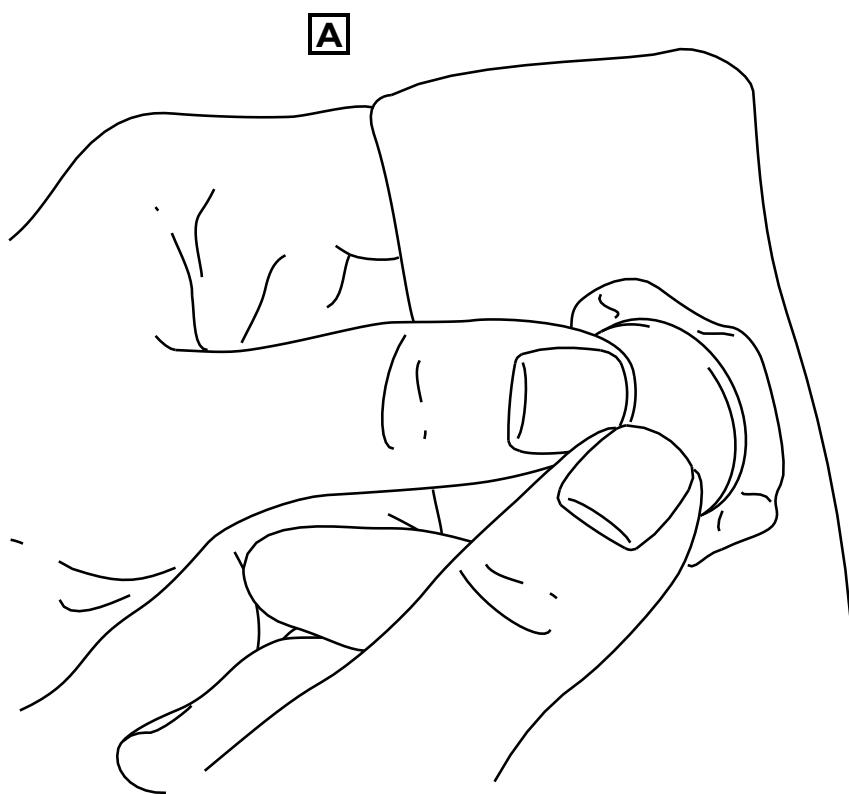
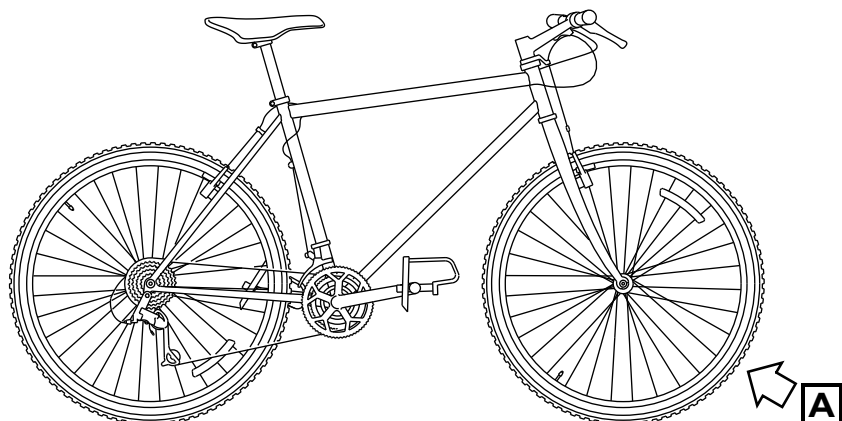

ICN-C0419-S1000D0378-001-01

Figure REP-5 Apply pressure to tube

13. Remove the thin cover from the patch.
14. Put a very thin layer of talcum powder on and around the patch.
15. Inflate (not fully) the repaired tube with the foot pump.
16. Start at the valve stem and install the tube again between the tire and the rim.
17. Push the valve stem through the hole in the rim.
18. Make sure that the valve stem is straight.
19. Install the remaining of the tire.

End of S1000DBIKE-AAA-D00-00-00-00AA-663A-A

S1000DBIKE-AAA-D00-00-01-00AA-933A-A

20. PREPARATION

APPLIC: Mountain bicycle and (Mountain storm Mk1 or Brook trekker Mk9)

- A. Remove the front wheel, refer to: [S1000DBIKE-AAA-DA0-30-00-00AA-520A-A](#)

APPLIC: Mountain bicycle and (Mountain storm Mk1 or Brook trekker Mk9)

- B. Remove the front brakes, refer to: [S1000DBIKE-AAA-DA1-20-00-00AA-520A-A](#)

21. PROCEDURE

APPLIC: Mountain bicycle and (Mountain storm Mk1 or Brook trekker Mk9)

- A. Remove the fork, refer to: [S1000DBIKE-AAA-D00-00-01-00AA-520A-A](#)

APPLIC: Mountain bicycle and (Mountain storm Mk1 or Brook trekker Mk9)

- B. Change the bike axis,

APPLIC: Mountain bicycle and Mountain storm Mk1

- C. Install the new fork, refer to: [S1000DBIKE-AAA-D00-00-01-00AA-720A-A](#)

APPLIC: Mountain bicycle and Brook trekker Mk9

- D. Install the new fork, refer to: [S1000DBIKE-AAA-D00-00-01-00AB-720A-A](#)

APPLIC: Mountain bicycle and (Mountain storm Mk1 or Brook trekker Mk9)

- E. Install the front brakes, refer to: [S1000DBIKE-AAA-DA1-20-00-00AA-720A-A](#)

APPLIC: Mountain bicycle and (Mountain storm Mk1 or Brook trekker Mk9)

- F. Install the front wheel, refer to: [S1000DBIKE-AAA-DA0-30-00-00AA-720A-A](#)

22. TEST

APPLIC: Mountain bicycle and (Mountain storm Mk1 or Brook trekker Mk9)

- A. Test that the fork is properly installed, refer to: [S1000DBIKE-AAA-D00-00-01-00AA-341A-A](#)

APPLIC: Mountain bicycle and (Mountain storm Mk1 or Brook trekker Mk9)

- B. Front brakes test, refer to: [BRAKE-AAA-DA1-00-00-00AA-341A-A](#)

End of S1000DBIKE-AAA-D00-00-01-00AA-933A-A

S1000DBIKE-AAA-DA0-10-20-00AA-215A-A

23. Inflating the tire

Ensure bicycle is on the repair stand.

24. Locate the deflated tire.
25. Attach the outlet valve of the [Tool \(1\) \(Foot pump \(PN BSK-TLST-001-05\)\)](#), from the [Tool \(4\) \(Specialist toolset \(PN BSK-TLST-001\)\)](#), to the valve of the deflated tire.
26. Inflate the tire.
 - A. Operate the foot pump to pump air into the tire.

- B. Check tire pressure. Refer to [S1000DBIKE-AAA-DA0-10-20-00AA-362B-A](#)

End of S1000DBIKE-AAA-DA0-10-20-00AA-215A-A

End of REPAIR

INTENTIONALLY BLANK

Assemble

Table ASSY-1 Support equipment

Name/Alternate name	Identification/Reference	MFR	Quantity	Remarks
(1) Clean dry cloth	BSK-TLST-001-12	KZ666	1 EA	
(2) Extra firm hold hairspray	HSP-D001	HS111	1 EA	
(3) Set of Allen wrenches	BSK-TLST-001-13	KZ666	1 EA	
(4) Specialist toolset	BSK-TLST-001	KZ666	1 EA	
(5) Tire lever	BSK-TLST-001-04	KZ666	1 EA	
(6) Tire pressure guage	BSK-TLST-001-01	KZ666	1 EA	
(7) Work stand	Stand-001	KZ555	1 EA	
(8) Work stand	Stand-001	Stand	1 EA	

Table ASSY-2 Consumables, materials and expendables

Name/Alternate name	Identification/Reference	MFR	Quantity	Remarks
(1)	BSB-DUROFIX_FIXATIF_UW		1	
(2)	BSB-DUROFIX_FIXATIF_UW_SPECIAL		1	
(3) General grease	LL-005	KZ222	As required	
(4) General lubricant	LL-001	KZ222	1 L	
(5) Rubbing alcohol	LL-002	KZ222	1 L	

Table ASSY-3 Spares

Name/Alternate name	Identification/Reference	MFR	Quantity	Remarks
(1) Brake cable hangar	BR-LVRS-002	KT444	1 EA	
(2) Brake lever	BR-LVRS-001	KT444	1 EA	
(3) Brake lever mount	BR-LVRS-001-01	KT444	1 EA	
(4) Conical expansion washer	St-001-05	KZ555	1 EA	
(5) Dust seal	St-001-04	KZ555	1 EA	
(6) Fork	FK-TEL1002	KZ666	1 EA	
- Fork	FK-TEL1002	KZ666	1 EA	
(7) Fork set	SPA-1000-1	KZ666	1 EA	
- Fork	FK-TEL1001	KZ666	1 EA	
(8) Frame fork	St-001-02	KZ555	1 EA	

Name/Alternate name	Identification/Reference	MFR	Quantity	Remarks
(9) Handlebar	Hd-001	KZ555	1 EA	
(10) Handlebar grips	Hd-001-01	KZ555	1 EA	
(11) Handlebar plug	Hd-001-02	KZ555	1 EA	
(12) Shifter lever	Sl-001	KZ555	1 EA	
(13) Stem	St-001	KZ555	1 EA	
(14) Stem bolt	St-001-01	KZ555	1 EA	
(15) Tire	TIRES-010101	KT666	1 EA	
(16) Upper bearing cup	St-001-03	KZ555	1 EA	

S1000DBIKE-AAA-D00-00-01-00AA-720A-A

1. Fork Installation

Apply grease ([Supply \(3\) \(General grease \(PN LL-005\)\)](#)) on the headset

- Install the headset, refer to: [S1000DBIKE-AAA-DA2-30-00-00AA-720A-A](#)
- To install the spacers, refer to: [S1000DBIKE-AAA-DA2-40-00-00AA-720A-A](#)
- Install the stem, refer to: [S1000DBIKE-AAA-DA2-10-00-00AA-720A-A](#)
- Install the fork ([Spare \(7\) \(Fork \(PN FK-TEL1001\)\)](#))

End of S1000DBIKE-AAA-D00-00-01-00AA-720A-A

S1000DBIKE-AAA-D00-00-01-00AB-720A-A

6. Fork installation

Apply grease ([Supply \(3\) \(General grease \(PN LL-005\)\)](#)) on the headset

- Install the headset, refer to: [S1000DBIKE-AAA-DA2-30-00-00AA-720A-A](#)
- Install the stem, refer to: [S1000DBIKE-AAA-DA2-10-00-00AA-720A-A](#)
- Install the fork ([Spare \(6\) \(Fork \(PN FK-TEL1002\)\)](#))

End of S1000DBIKE-AAA-D00-00-01-00AB-720A-A

S1000DBIKE-AAA-D00-00-01-00AB-720A-A

10. Fork installation

Apply grease ([Supply \(3\) \(General grease \(PN LL-005\)\)](#)) on the headset

- Install the headset, refer to: [S1000DBIKE-AAA-DA2-30-00-00AA-720A-A](#)
- Install the stem, refer to: [S1000DBIKE-AAA-DA2-10-00-00AA-720A-A](#)
- Install the fork ([Spare \(6\) \(Fork \(PN FK-TEL1002\)\)](#))

End of S1000DBIKE-AAA-D00-00-01-00AB-720A-A

S1000DBIKE-AAA-DA0-10-20-00AA-921A-A

14. Tire replacement

Lift and turn the bicycle and make sure the bicycle is held safely in this position.

- Use a standard wrench from the [Tool \(4\) \(Specialist toolset \(PN BSK-TLST-001\)\)](#) and loosen the brake caliper.

16. Remove the axle bolt.
17. Remove the wheel.
18. Deflate the tire.
19. Use the [Tool \(5\) \(Tire lever \(PN BSK-TLST-001-04\)\)](#) from the [Tool \(4\) \(Specialist toolset \(PN BSK-TLST-001\)\)](#) and remove the old tire from the wheel.
20. Use the [Tool \(5\) \(Tire lever \(PN BSK-TLST-001-04\)\)](#) from the [Tool \(4\) \(Specialist toolset \(PN BSK-TLST-001\)\)](#) and attach the new [Spare \(15\) \(Tire \(PN TIRES-010101\)\)](#) to the wheel. Refer to [S1000DBIKE-AAA-DA0-00-00-00AA-041A-A](#)
21. Inflate the tire (refer to [S1000DBIKE-AAA-DA0-10-20-00AA-215A-A](#)).
22. Install the wheel.
23. Tighten the axle bolt.
24. Tighten the brake caliper.

Requirements after job completion

Required conditions

Table ASSY-4 Required conditions

Actions/Condition	Data module/Technical publication
Lift and turn the bicycle to the correct position.	
Do a test of the brakes as given in the brake test procedure.	S1000DBIKE-AAA-DA1-00-00-00AA-341A-A

End of S1000DBIKE-AAA-DA0-10-20-00AA-921A-A

S1000DBIKE-AAA-DA0-30-00-00AA-720A-A

25. Front wheel installation

Note

It is necessary to install the fork and the brakes before installing the wheel

26. Hold the front of the bicycle.
27. Install the wheel with ([Tool \(4\) \(Specialist toolset \(PN BSK-TLST-001\)\)](#)) and be careful to not damage the chainring.
28. Put the bike on the floor.

End of S1000DBIKE-AAA-DA0-30-00-00AA-720A-A

S1000DBIKE-AAA-DA1-20-00-00AA-720A-A

29. Front brake installation

Note

It is necessary to install the fork before installing the brakes

30. Hold the front of the bicycle.
31. Install the front brakes on the fork.
32. Put the frame on the floor.

End of S1000DBIKE-AAA-DA1-20-00-00AA-720A-A

S1000DBIKE-AAA-DA2-10-00-00AA-720A-A

Preliminary requirements

Required conditions

Table ASSY-5 Required conditions

Actions/Condition	Data module/Technical publication
Make sure the bicycle is held safely on a work stand with the front wheel free of the ground	

Safety conditions

CAUTION

Do not tighten the stem bolt too much. You can cause damage to the headset bearings if you tighten the stem too much.

CAUTION

The stem bolt does not safety the stem.

Note

The stem must point forward in alignment with the wheel.

33. Stem installation

Remove all the rust and the corrosion with a [Tool \(1\) \(Clean dry cloth \(PN BSK-TLST-001-12\)\)](#) and [Supply \(5\) \(Rubbing alcohol \(PN LL-002\)\)](#).

34. Install the stem.

A. Use a [Supply \(4\) \(General lubricant \(PN LL-001\)\)](#) and lubricate:

- the threads of the [Spare \(13\) \(Stem \(PN St-001\)\)](#) and [Spare \(14\) \(Stem bolt \(PN St-001-01\)\)](#)
- the sides
- the top of the wedge

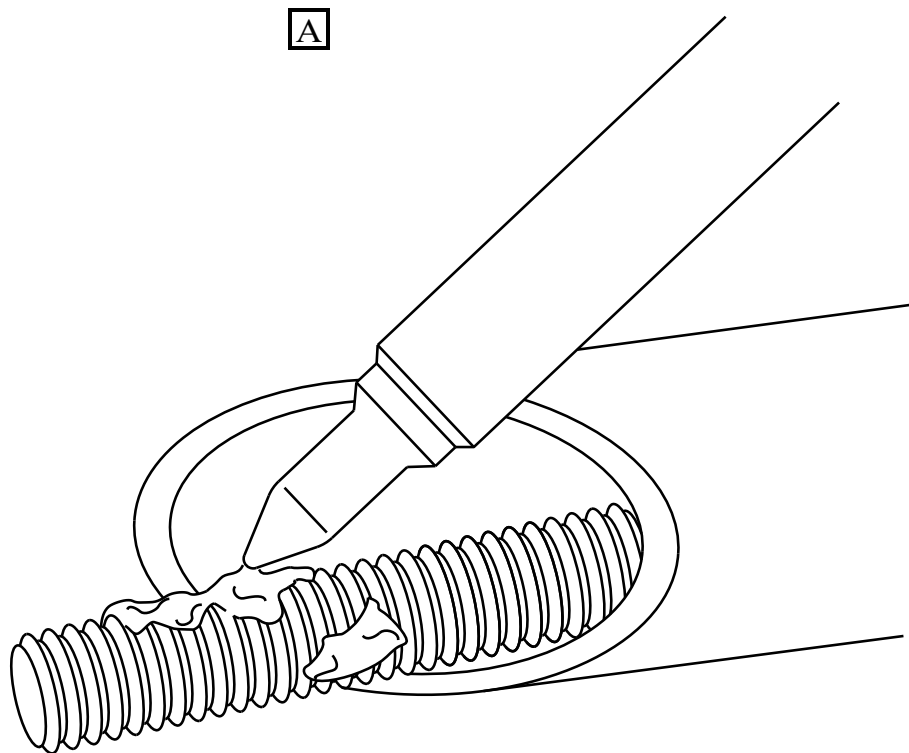
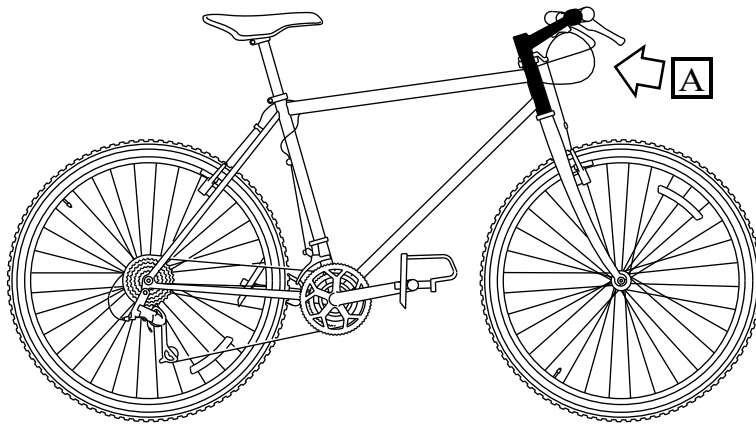

ICN-C0419-S1000D0385-001-01

Figure ASSY-1 Lubricate the thread

- B. Install the [Spare \(13\) \(Stem \(PN St-001\)\)](#) in the steerer tube.

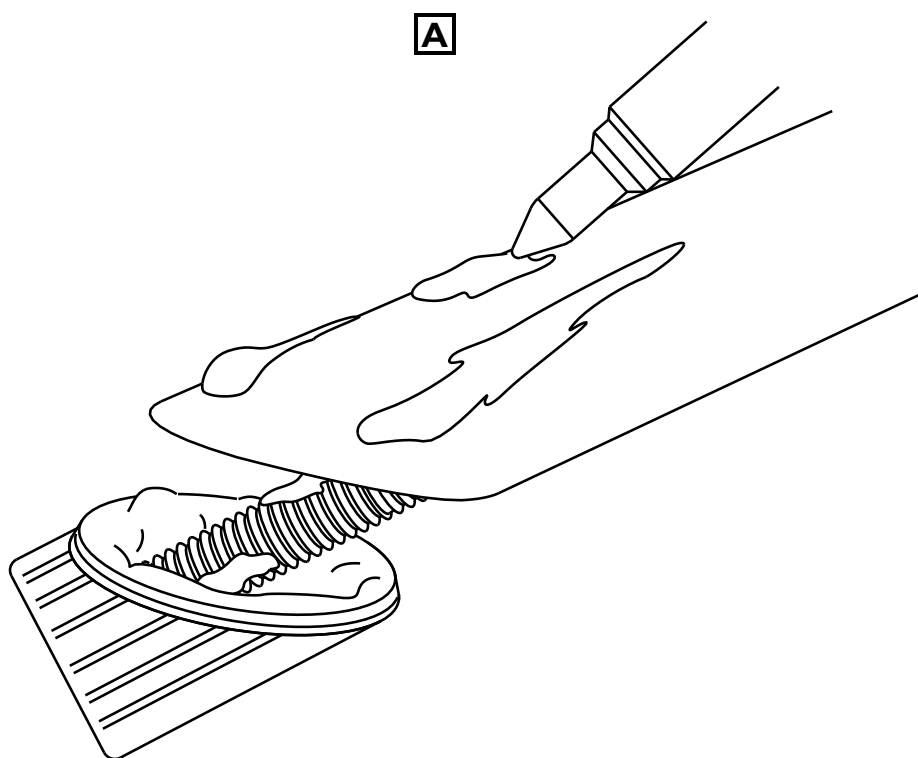
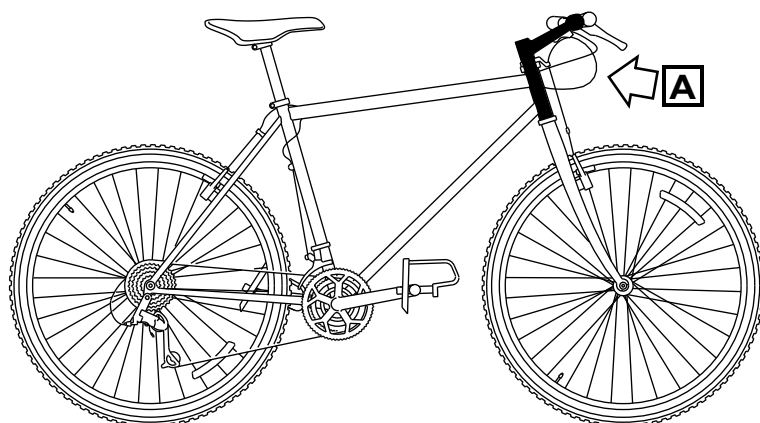

ICN-C0419-S1000D0386-001-01

Figure ASSY-2 Tighten the bolt

- C. Adjust to align the [Spare \(13\) \(Stem \(PN St-001\)\)](#) with the wheel and tighten the [Spare \(14\) \(Stem bolt \(PN St-001-01\)\)](#) firmly.
35. Install the handlebars (refer to [S1000DBIKE-AAA-DA2-20-00-00AA-720A-A](#)).

End of S1000DBIKE-AAA-DA2-10-00-00AA-720A-A

S1000DBIKE-AAA-DA2-20-00-00AA-720A-A

Preliminary requirements

Required conditions

Table ASSY-6 Required conditions

Actions/Condition	Data module/Technical publication
The bicycle is held safely on work stand. Refer to (Tool (7) (Work stand (PN Stand-001)))	

Safety conditions

WARNING

Do not ride the bicycle until the grips have become dry and are firmly held in position. If the grips are wet, your hands can move off the grips when you ride the bicycle.

WARNING

Do not ride a bicycle with no grips on the handlebar.

CAUTION

Make sure the handlebar is correctly aligned in the center of the stem.

36. Handlebar installation

Put the [Spare \(9\) \(Handlebar \(PN Hd-001\)\)](#) in the stem and tighten the clamp bolt with a [Tool \(3\) \(Set of Allen wrenches \(PN BSK-TLST-001-13\)\)](#). Make sure the handlebar is correctly aligned in the center of the stem. Tighten the clamp bolt.

37. Put the [Spare \(2\) \(Brake lever \(PN BR-LVRS-001\)\)](#) and [Spare \(12\) \(Shifter lever \(PN SI-001\)\)](#) on the handlebar.
- Move the [Spare \(12\) \(Shifter lever \(PN SI-001\)\)](#) on the [Spare \(9\) \(Handlebar \(PN Hd-001\)\)](#) again and make sure you do not catch the cables.
 - Tighten the clamp bolt.
 - Move the [Spare \(3\) \(Brake lever mount \(PN BR-LVRS-001-01\)\)](#) and the brake lever on the [Spare \(9\) \(Handlebar \(PN Hd-001\)\)](#) again.
 - Tighten the clamp screw.
38. Replace the [Spare \(10\) \(Handlebar grips \(PN Hd-001-01\)\)](#).
- Apply with the [Tool \(2\) \(Extra firm hold hairspray \(PN HSP-D001\)\)](#) to the [Spare \(10\) \(Handlebar grips \(PN Hd-001-01\)\)](#) area of the [Spare \(3\) \(Brake lever mount \(PN BR-LVRS-001-01\)\)](#).
 - Before the [Tool \(2\) \(Extra firm hold hairspray \(PN HSP-D001\)\)](#) becomes dry, move the [Spare \(10\) \(Handlebar grips \(PN Hd-001-01\)\)](#) into the correct position. Make sure the grip protects the end of the [Spare \(9\) \(Handlebar \(PN Hd-001\)\)](#) or install a [Spare \(11\) \(Handlebar plug \(PN Hd-001-02\)\)](#).

End of S1000DBIKE-AAA-DA2-20-00-00AA-720A-A

S1000DBIKE-AAA-DA2-30-00-00AA-720A-A

Preliminary requirements

Required conditions

Table ASSY-7 Required conditions

Actions/Condition	Data module/Technical publication
The bicycle is safely held on a work stand	

39. Headset installation

Install the [Spare \(8\) \(Frame fork \(PN St-001-02\)\)](#) on the frame.

40. Install the [Spare \(16\) \(Upper bearing cup \(PN St-001-03\)\)](#).

41. Install the components that follow on the steering tube:

- the [Spare \(1\) \(Brake cable hangar \(PN BR-LVRS-002\)\)](#)
- the [Spare \(5\) \(Dust seal \(PN St-001-04\)\)](#)
- the [Spare \(4\) \(Conical expansion washer \(PN St-001-05\)\)](#)

42. Install the stem (refer to [S1000DBIKE-AAA-DA2-10-00-00AA-720A-A](#)).

End of S1000DBIKE-AAA-DA2-30-00-00AA-720A-A

S1000DBIKE-AAA-DA2-40-00-00AA-720A-A

43. Spacer installation

Note

It is necessary to install the headset before installing any spacer

44. Install the spacer ([Spare \(7\) \(Spacer \(PN SPC-200-12\)\)](#))

End of S1000DBIKE-AAA-DA2-40-00-00AA-720A-A

S1000DLIGHTING-AAA-D00-00-00-00AA-700A-A

Preliminary requirements

Required conditions

Table ASSY-8 Required conditions

Actions/Condition	Data module/Technical publication
Bike is stationary	

45. Lighting assembly

Remove the lighting system from the packaging.

46. Make sure that the components in the package are the same as those on the [S1000DLIGHTING-AAA-D00-00-00-01AA-941A-D](#)

47. Install the light bulb to the front and rear lights (refer to [S1000DLIGHTING-AAA-D00-00-00-00AA-921A-A](#)).

48. Attach the front light fitting on the top of the handlebar.

- A. Apply the protective strip around the handlebar.
- B. Pull the clamp open and put it around the protective strip with the light connector at the top.

- C. Install the washer on the screw.
 - D. Use the correct screwdriver from the [Tool \(4\) \(Specialist toolset \(PN BSK-TLST-001\)\)](#) and tighten the screw into the hole at the bottom of the clamp. This safeties the clamp to the handlebar.
49. Attach the rear light fitting to the rear triangle of the bike frame.
- A. Apply the protective strip around one of the two rear triangle up-tubes.
 - B. Pull the clamp open and put it around the protective strip. Make sure the light connector points rearwards.
 - C. Install the washer on the screw.
 - D. Use the correct screwdriver from the [Tool \(4\) \(Specialist toolset \(PN BSK-TLST-001\)\)](#) and tighten the screw into the hole at the bottom of the clamp. This safeties the clamp to the tube.
50. Attach the light with the white glass to the front connector.
51. Attach the light with the red glass to the rear connector.

End of S1000DLIGHTING-AAA-D00-00-00-00AA-700A-A

End of ASSEMBLE

Storage

Table STORE-1 Support equipment

Name/Alternate name	Identification/Reference	MFR	Quantity	Remarks
(1) Specialist toolset	BSK-TLST-001	KZ666	1 EA	
(2) Test stand	BSK-TLST-999-01	KZ666	1 EA	
(3) 8mm Allen wrench	BSK-TLST-001-08	KZ666	1 EA	

Table STORE-2 Consumables, materials and expendables

Name/Alternate name	Identification/Reference	MFR	Quantity	Remarks
N/A	N/A	N/A	N/A	N/A

Table STORE-3 Spares

Name/Alternate name	Identification/Reference	MFR	Quantity	Remarks
(1) Horn	Horn-001	KZ444	1 EA	

S1000DBIKE-AAA-D00-00-00-00AA-330A-A

WARNING

PSE Footware should be worn at all times during these operations

CAUTION

Stands may not be secured and may move during operation

Preliminary requirements

Safety conditions

WARNING

PSE Footware should be worn at all times during these operations

1. Test Stand

WARNING

PSE Footware should be worn at all times during these operations

Ensure [Tool \(2\) \(Test stand \(PN BSK-TLST-999-01\)\)](#) is level.

CAUTION

Stands may not be secured and may move during operation

- Place bicycle on the test stand.
- Tighten clamps until bicycle is securely attached to the test stand.

End of S1000DBIKE-AAA-D00-00-00-00AA-330A-A

S1000DBIKE-AAA-DA3-10-00-00AA-921A-A

4. Horn replacement

Safely hold the bicycle.

- Remove the horn.

-
- A. Use the 8mm Allen wrench from the [Tool \(1\) \(Specialist toolset \(PN BSK-TLST-001\)\)](#) and remove the two Allen screws.
 - B. Remove the horn.
6. Install the new [Spare \(1\) \(Horn \(PN Horn-001\)\)](#).
- A. Install the new [Spare \(1\) \(Horn \(PN Horn-001\)\)](#) on the handlebars.
 - B. Use the [Tool \(3\) \(8mm Allen wrench \(PN BSK-TLST-001-08\)\)](#) from the [Tool \(1\) \(Specialist toolset \(PN BSK-TLST-001\)\)](#) and tighten the two Allen screws.

Requirements after job completion

Required conditions

Table STORE-4 Required conditions

Actions/Condition	Data module/Technical publication
Safely discard the horn that you removed	(Local Disposal Procedures)

End of S1000DBIKE-AAA-DA3-10-00-00AA-921A-A

End of STORAGE

End of MAINTENANCE AND SERVCING

Illustrated Parts Data

Illustrated parts data

S1000DBIKE-AAA-D00-00-00-00AA-941A-C

1. Introduction

This section provides illustrations and parts breakdown of all parts of the lavatory assembly shown on the title page which can be disassembled, repaired or replaced and reassembled.

2. Explanation and Usage of Section.

A. Assembly Order Indenture System.

The Indenture system used in the parts list shows the relationship of one part to another. For a given item, the number of indentures depicts the relationship of the item to the associated next higher assembly as follows:

1 2 3

Assembly

. Detail Parts for Assembly

. Attaching Parts for Assembly

. . Subassembly

. . Attaching parts for Subassembly

. . . Detail parts for subassembly

. . . Attaching parts for Detail parts

B. Part Numbering System.

A typical part number e.g. C22101-123-345 is split into four parts.

C22101-123-345

is the project, in this case a lavatory for a Boeing 737

C22101-123-345

is a variant, 101, 201, 301 refers to the position of the lavatory in the aircraft

C22101-123-345

is the drawing

C22101-123-345

is the part identity. Part identities are in groups

001-099 assemblies

101-299 individual parts

301-499 coloured assemblies

601-799 unfinished, i.e. complete except for colour

801-998 coloured parts

RGS numbers are frequently used standard parts or assemblies.

RES numbers are frequently used electrical standard parts or assemblies.

C. Effectivity Code.

Reference letters (A, B, C, etc.) are assigned to the EFF CODE column to each top assembly, in each IPL figure. The reference letter of the applicable top assembly is also shown in the EFF CODE

column for each detail part and subassembly except that no reference letter is shown for detail parts and subassemblies used on all top assemblies.

Note

The effectivity code shall identify affected parts within a single figure only. The same code may appear in other figures, but it is only to be used for those parts within the figure in which it is listed. Effectivity does not necessarily relate to more than one figure.

D. Units Per Assembly.

The UNITS PER ASSY column shows the total number of units required per assembly, per subassembly, and per sub-subassembly as applicable. For bulk items, the letters AR indicate "as required". The letters RF indicate the item is listed for reference purposes.

E. Parts Replacement Data.

The interchangeability relationship between parts is identified in the NOMENCLATURE column of the parts list. A list of the terms used to show interchangeability and their definition is as follows:

Table IPD-1 Interchangeability Definitions

TERM	PARTS LIST ABBREVIATION	DEFINITION
Optional	OPT	This part is optional to and interchangeable with other parts in the same item number variant group or other item number if designated.
Superseded by	SUPSD BY	The part in the part number column is replaced by and is not interchangeable with the item number shown in the notation.
Supersedes	SUPSDS	The part in the part number column replaces and is not interchangeable with the item number shown in the notation.
Replaced by	RPLD BY	The part in the part number column is replaced by and interchangeable with the item number shown in the notation.
Replaces	RPLS	The part in the part number column replaces and is interchangeable with the item number shown in the notation.
blah		
blah		
blah		
blah		

F. Items Not Illustrated.

Items not illustrated are indicated by a dash (-) ahead of the item number in the FIG. and ITEM NO column.

G. Alpha Variant Item Numbers.

Alpha variants A-Z (except I and O) are assigned to existing item number when necessary to show:

1. Added items.
2. Service Bulletin modifications
3. Configuration differences
4. Optional parts
5. Product improvement parts (non-service bulletin)

Alpha variant item numbers are not shown on the exploded view when the appearance and location of the alpha variant item is the same as the basic item.

End of S1000DBIKE-AAA-D00-00-00-00AA-941A-C

End of INTRODUCTION

INTENTIONALLY BLANK

Numerical index

This section contains the NI for the IPD section for the components listed in this publication.

Part number	Airline stock number	Figure	Item	Quantity
A0010		D00-00-00-01A	037A	RF
AVLNO12345678901234 56		D00-00-00-01A	005A	RF
AVLNO12345678901234 56		D00-00-00-01A	026A	RF
AVLNO12345678901234 56		D00-00-00-01A	027A	RF
AVLNO12345678901234 56		D00-00-00-01A	028A	RF
AVLNO12345678901234 56		D00-00-00-01A	029A	RF
AVLNO12345678901234 56		D00-00-00-01A	030A	RF
AVLNO12345678901234 56		D00-00-00-01A	031A	RF
AVLNO12345678901234 56		D00-00-00-01A	032A	RF
AVLNO12345678901234 56		D00-00-00-01A	033A	RF
AVLNO12345678901234 56		D00-00-00-01A	034A	RF
AVLNO12345678901234 56		D00-00-00-01A	035A	RF
AVLNO12345678901234 56		D00-00-00-01A	036A	RF
AVLNO12345678901234 56		D00-00-00-01A	037A	RF
AVLNO12345678901234 56		D00-00-00-01A	038A	RF
AVLNO12345678901234 56		D00-00-00-01A	039A	RF
AVLNO12345678901234 56		D00-00-00-01A	040A	RF
AVLNO12345678901234 56		D00-00-00-01A	041A	RF
AVLNO12345678901234 56		D00-00-00-01A	042A	RF
AVLNO12345678901234 56		D00-00-00-01A	043A	RF

COMPONENT MAINTENANCE PUBLICATION

S1000DBIKE-KD559-CMPXX-00

TEST

Part number	Airline stock number	Figure	Item	Quantity
AVLNO12345678901234 56		D00-00-00-01A	044A	RF
AVLNO12345678901234 56		D00-00-00-01A	045A	RF
AVLNO12345678901234 56		D00-00-00-01A	046A	RF
BICYCLE-001		D00-00-00-01A	000A	REF
BICYCLE-001		D00-00-00-01A	000A	REF
BICYCLE-0011		D00-00-00-01A	001A	1
BICYCLE-0011		D00-00-00-01A	001A	1
BICYCLE-0012A		D00-00-00-01A	002A	1
BICYCLE-0012A		D00-00-00-01A	002A	1
BICYCLE-0012B		D00-00-00-01A	002A	1
BICYCLE-0012B		D00-00-00-01A	002A	1
BICYCLE-0013		D00-00-00-01A	003A	1
BICYCLE-0013		D00-00-00-01A	003A	1
BICYCLE-0014		D00-00-00-01A	004A	1
BICYCLE-0014		D00-00-00-01A	004A	1
BICYCLE-0014		D00-00-00-01A	016A	1
BICYCLE-0014		D00-00-00-01A	017A	1
BICYCLE-0014		D00-00-00-01A	018A	1
BICYCLE-0014		D00-00-00-01A	019A	1
BICYCLE-0014		D00-00-00-01A	020A	1
BICYCLE-0014		D00-00-00-01A	021A	1
BICYCLE-0014		D00-00-00-01A	022A	1
BICYCLE-0014		D00-00-00-01A	023A	1
BICYCLE-0014		D00-00-00-01A	024A	1
BICYCLE-0014		D00-00-00-01A	025A	1
BICYCLE-0015		D00-00-00-01A	005A	1
BICYCLE-0015		D00-00-00-01A	005A	1
BICYCLE-0015		D00-00-00-01A	026A	1
BICYCLE-0015		D00-00-00-01A	027A	1
BICYCLE-0015		D00-00-00-01A	028A	1
BICYCLE-0015		D00-00-00-01A	029A	1
BICYCLE-0015		D00-00-00-01A	030A	1
BICYCLE-0015		D00-00-00-01A	031A	1

ILLUSTRATED PARTS DATA

CTM23-10-10

2018-03-01

Page IPD-6

Part number	Airline stock number	Figure	Item	Quantity
BICYCLE-0015		D00-00-00-01A	032A	1
BICYCLE-0015		D00-00-00-01A	033A	1
BICYCLE-0015		D00-00-00-01A	034A	1
BICYCLE-0015		D00-00-00-01A	035A	1
BICYCLE-0015		D00-00-00-01A	036A	1
BICYCLE-0015		D00-00-00-01A	037A	1
BICYCLE-0015		D00-00-00-01A	038A	1
BICYCLE-0015		D00-00-00-01A	039A	1
BICYCLE-0015		D00-00-00-01A	040A	1
BICYCLE-0015		D00-00-00-01A	041A	1
BICYCLE-0015		D00-00-00-01A	042A	1
BICYCLE-0015		D00-00-00-01A	043A	1
BICYCLE-0015		D00-00-00-01A	044A	1
BICYCLE-0015		D00-00-00-01A	045A	1
BICYCLE-0015		D00-00-00-01A	046A	1
CP-001		D00-00-00-01A	009A	1
CP-001		D00-00-00-01A	009A	1
CP-001		D00-00-00-01A	010A	1
CP-001		D00-00-00-01A	011A	1
CP-001		D00-00-00-01A	012A	1
CP-001		D00-00-00-01A	013A	1
CP-001		D00-00-00-01A	014A	1
CP-001		D00-00-00-01A	015A	1
LIRUS-B1-12F		D00-00-00-01	020A	1
LIRUS-B1-12R		D00-00-00-01	021A	1
LIRUS-G1-10		D00-00-00-01	022A	2
LIRUS-G1-10H		D00-00-00-01	023A	1
LIRUS-L1-10		D00-00-00-01	005A	2
LIRUS-L1-11		D00-00-00-01	010A	2
LRU-B001		D00-00-00-01	012A	1
LRU-B003		D00-00-00-01	013A	1
LRU-B124		D00-00-00-01	014A	1
LRU-B556		D00-00-00-01	015A	1
LRU-B789		D00-00-00-01	016A	1
LRU1001		D00-00-00-01	000A	REF

Part number	Airline stock number	Figure	Item	Quantity
LRU1001		D00-00-00-01A	006A	1
LRU1001		D00-00-00-01A	006A	1
LRU1010		D00-00-00-01	001A	1
LRU1011		D00-00-00-01	002A	1
LRU1011		D00-00-00-01	018A	1
LRU1012		D00-00-00-01	003A	1
LRU1013		D00-00-00-01	004A	1
LRU1018		D00-00-00-01	006A	1
LRU1019		D00-00-00-01	007A	1
LRU1020		D00-00-00-01	009A	1
LRU1022		D00-00-00-01	008A	1
LRU1026		D00-00-00-01	011A	1
LRU2010		D00-00-00-01	017A	1
LRU2018		D00-00-00-01	019A	1
LTD001		D00-00-00-01A	006A	RF
Q123345		D00-00-00-01A	012A	RF
QT007		D00-00-00-01A	013A	RF
TT001		D00-00-00-01A	014A	RF
WH-001		D00-00-00-01A	007A	1
WH-001		D00-00-00-01A	007A	1
WH-002		D00-00-00-01A	008A	1
WH-002		D00-00-00-01A	008A	1

End of NUMERICAL INDEX

Equipment designator index

This section contains the EDI for the IPD section for the components listed in this publication.

Equipment designator	GEO LOC	Figure	Item	Equipment designator	GEO LOC	Figure	Item
123456		D00-00-00-01	000A	FIN007		D00-00-00-01A	025A
456		D00-00-00-01	000A	FIN012		D00-00-00-01A	026A
FIN002	GEO123	D00-00-00-01A	005A	FIN013		D00-00-00-01A	026A
FIN003	GEO123	D00-00-00-01A	005A	FIN014		D00-00-00-01A	026A
FIN004	GEO124	D00-00-00-01A	005A	FIN015		D00-00-00-01A	026A

End of EQUIPMENT DESIGNATOR INDEX

INTENTIONALLY BLANK

S1000DBIKE-AAA-D00-00-00-01AA-941A-D

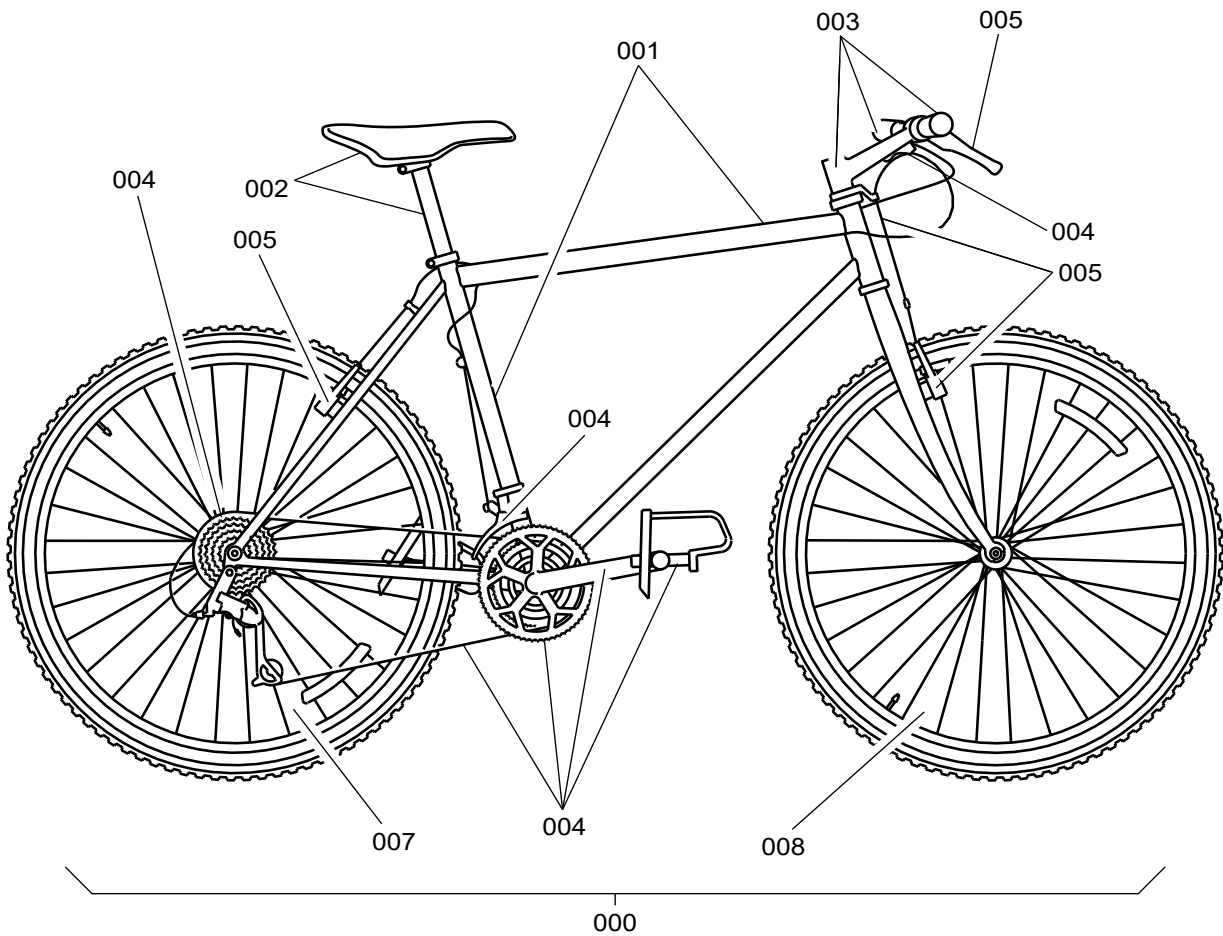

ICN-C0419-S1000D0361-001-01

IPD Figure D00-00-00-01A Bicycle

ILLUSTRATED PARTS DATA

2018-03-01

Page IPD-12

CTM23-10-10

Copyright (C) 2025 by Contiem Ltd

IPD figure D00-00-00-01A — Bicycle

Item	Part number	MFR	Description	QNHA	UOC
000A	BICYCLE-001	KZ999	Bicycle (ADDED) (MOD SP) (ADDED) (MOD KZ999:LNS10276051) (MOD 8145144345) (MOD F2408:1-4UD:02)	REF	
001A	BICYCLE-0011	KZ999	• Frame assembly	1	
002A	BICYCLE-0012A	KZ999	•• Seat, assembly	1	
002A	BICYCLE-0012B	KZ999	•• Cruiser Seat, assembly	1	
003A	BICYCLE-0013	KZ999	•• Steering system	1	
004A	BICYCLE-0014	KZ999	•• Drive train system	1	
005A	BICYCLE-0015	KZ999	•• Brake sub-system	1	
006A	LRU1001	KZ777	•• Light system	1	
007A	WH-001	KZ888	•• Wheel, assembly rear	1	
008A	WH-002	KZ888	•• Wheel, assembly front	1	
009A	CP-001	KZ888	•• Computer	1	

End of S1000DBIKE-AAA-D00-00-00-01AA-941A-D

S1000DLIGHTING-AAA-D00-00-00-01AA-941A-D

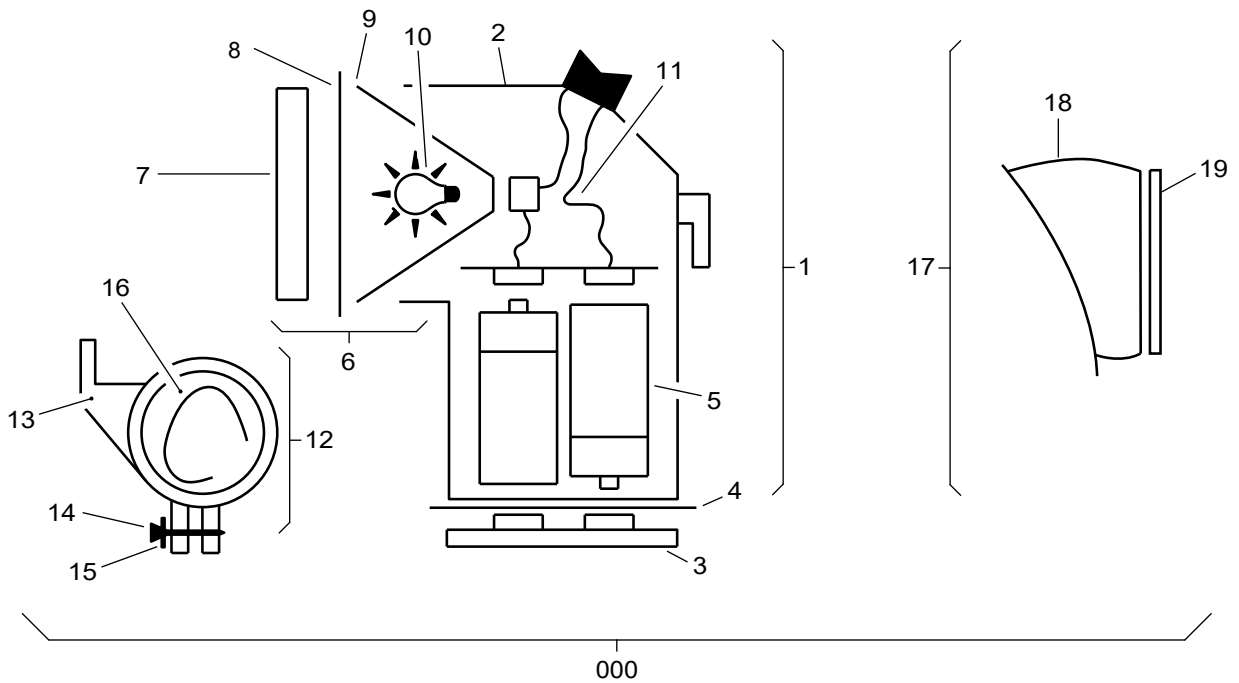

ICN-C0419-S1000D0362-001-01

IPD Figure D00-00-00-01 Light system

ILLUSTRATED PARTS DATA

2018-03-01

Page IPD-15

CTM23-10-10

Copyright (C) 2025 by Contiem Ltd

IPD figure D00-00-00-01 — Light system

Item	Part number	MFR	Description	QNHA	UOC
000A	LRU1001	KZ777	(REFER TO NHA S1000DBIKE-D00-00-00-01-999) (N/A ### Error unable to find target for reference to DMC-CSN-AAA-D00-00-00-01AA-941A-D ###) (PRE SB 123) (POST SB 123) (ATTACHING PART) (SELECT DURING TEST) (desc/location) (REFER TO NHA S1000DBIKE-D00-00-00-01-001) (N/A S1000DLIGHTING-AAA-D00-00-00-01AA-941A-D) (REF DES: 123456, 456)	REF	
001A	LRU1010	KZ777	• (FRONT)	1	
002A	LRU1011	KZ777	••	1	
003A	LRU1012	KZ777	•••	1	
004A	LRU1013	KZ777	••••	1	
005A	LIRUS-L1-10	KZ777	•••	2	
006A	LRU1018	KZ777	••	1	
007A	LRU1019	KZ777	•••	1	
008A	LRU1022	KZ777	••••	1	
009A	LRU1020	KZ777	•••	1	
010A	LIRUS-L1-11	KZ777	••••	2	
011A	LRU1026	KZ777	••	1	
012A	LRU-B001	KZ777	•	1	
013A	LRU-B003	KZ777	••	1	
014A	LRU-B124	KZ777	•• (ATTACHING PART)	1	
015A	LRU-B556	KZ777	•• (ATTACHING PART)	1	
016A	LRU-B789	KZ777	•••	1	
017A	LRU2010	KZ777	•	1	
018A	LRU1011	KZ777	•• (REAR)	1	
019A	LRU2018	KZ777	••	1	
020A	LIRUS-B1-12F	KZ777	•••	1	
021A	LIRUS-B1-12R	KZ777	•••	1	
022A	LIRUS-G1-10	KZ777	•••	2	
023A	LIRUS-G1-10H	KZ777	•••	1	

End of S1000DLIGHTING-AAA-D00-00-00-01AA-941A-D

S1000DBIKE-AAA-D00-00-00-02AA-941A-D

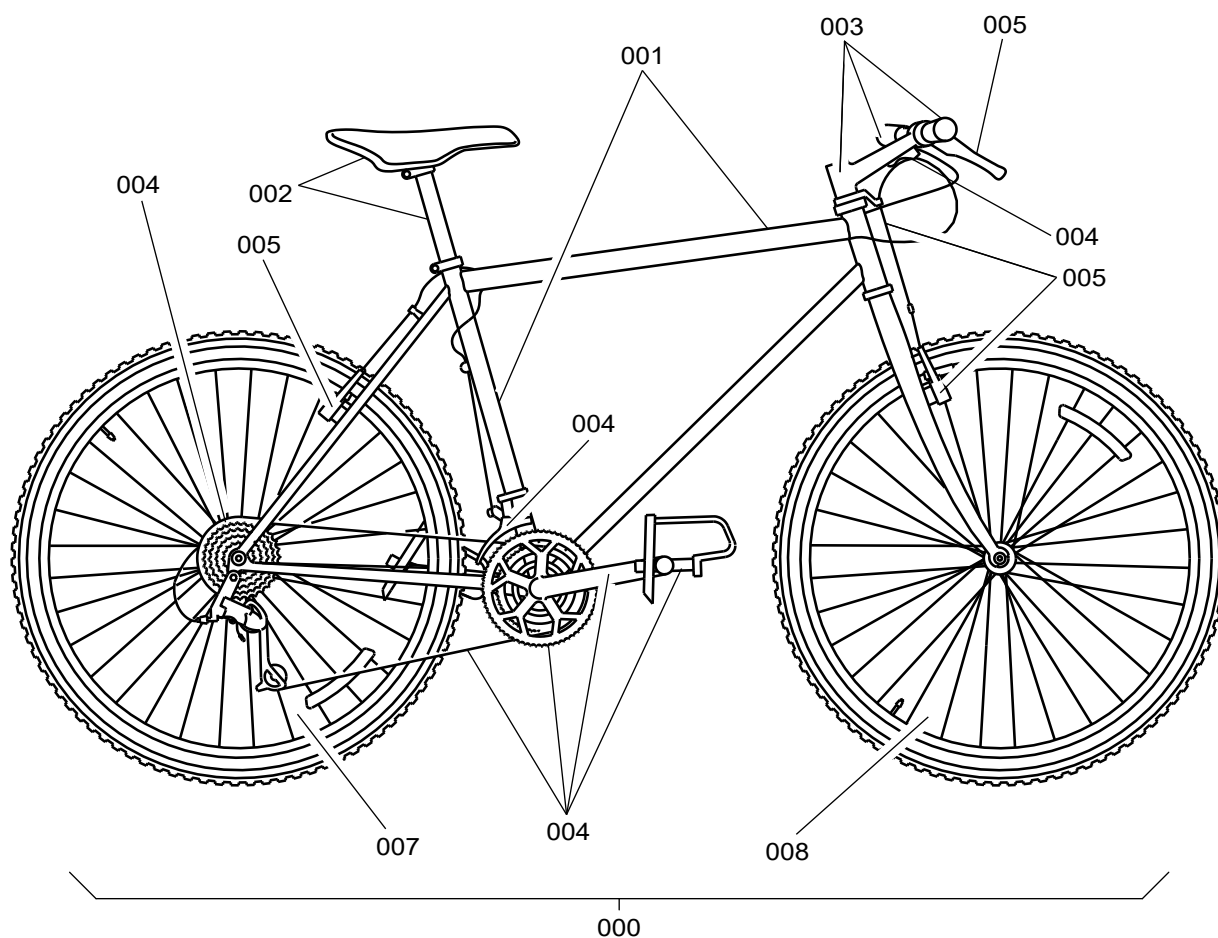

ICN-C0419-S1000D0361-001-01

IPD Figure D00-00-00-01A Bicycle test bits

ILLUSTRATED PARTS DATA

2018-03-01

Page IPD-18

CTM23-10-10

Copyright (C) 2025 by Contiem Ltd

IPD figure D00-00-00-01A — Bicycle test bits

Item	Part number	MFR	Description	QNHA	UOC
000A	BICYCLE-001	KZ999	Bicycle (REFER TO NHA S1000DBIKE-D00-00-00-01-001) (ADDED) (MOD SP) (ADDED) (MOD KZ999:LNS10276051) (MOD 8145144345) (MOD F2408:1-4UD:02)	REF	
001A	BICYCLE-0011	KZ999	• Frame assembly (FOR DETAILS REFER TO S1000DBIKE-D00-00-00-01-001)	1	
002A	BICYCLE-0012A	KZ999	•• Seat, assembly (FOR ATTACHING PARTS REFER TO S1000DBIKE-D00-00-00-01-001)	1	
002A	BICYCLE-0012B	KZ999	•• Cruiser Seat, assembly (FOR ATTACHING PARTS REFER TO S1000DBIKE-D00-00-00-01-001) (RPLS ITEM 001)	1	
003A	BICYCLE-0013	KZ999	•• Steering system (FOR SELECT FROM PARTS REFER TO S1000DBIKE-D00-00-00-01-001) (RPLD BY ITEM 001)	1	
004A	BICYCLE-0014	KZ999	•• Drive train system (FOR OVERSIZE/UNDERSIZE PART REFER TO S1000DBIKE-D00-00-00-01-001) (SUPSDS ITEM 001)	1	
005A	BICYCLE-0015	KZ999	•• Brake sub-system (ORIGINAL PART NUMBER: AVLNO1234567890123456) (REF DES: FIN002 THRU FIN004)	1	
006A	LRU1001	KZ777	•• Light system (LIMITED PART NUMBER: LTD001) (CUSTOMER STOCK NUMBER: CUS001)	1	
007A	WH-001	KZ888	•• Wheel, assembly rear (NON-PROCURABLE PART)	1	
008A	WH-002	KZ888	•• Wheel, assembly front (CSD AVJ001 (M1234)) (PLACARD TEXT: DO NOT ATTACH HERE)	1	
009A	CP-001	KZ888	•• Computer (SUPSD BY ITEM 004)	1	
010A	CP-001	KZ888	•• TEST DATA (OPT PART ITEM 001)	1	

COMPONENT MAINTENANCE PUBLICATION

S1000DBIKE-KD559-CMPXX-00

TEST

IPD figure D00-00-00-01A — Bicycle test bits

Item	Part number	MFR	Description	QNHA	UOC
011A	CP-001	KZ888	•• TEST DATA (PREFERRED SPARE ITEM 001)	1	
012A	CP-001	KZ888	•• TEST DATA (PREFERRED SPARE ITEM Q123345 (M1234))	1	
013A	CP-001	KZ888	•• TEST DATA (ALTERED FROM QT007 (M1234) OLD WIDGET)	1	
014A	CP-001	KZ888	•• TEST DATA (MANUFACTURED FROM TT001 (M1234))	1	
015A	CP-001	KZ888	•• TEST DATA (PRE SB SB-1234-PRE) (POST SB SB-1234-POST) (REF SB SB-777-REF) (RWK SB SB-3434-RWK)	1	
016A	BICYCLE-0014	KZ999	•• Drive train system (SUPSDS ITEM 001) (ATTACHING PART)	1	
017A	BICYCLE-0014	KZ999	•• Drive train system (SUPSDS ITEM 001) (SELECT DURING ASSEMBLY)	1	
018A	BICYCLE-0014	KZ999	•• Drive train system (SUPSDS ITEM 001) (SELECT DURING TEST)	1	
019A	BICYCLE-0014	KZ999	•• Drive train system (SUPSDS ITEM 001) (LOCALLY MANUFACTURE OR PROGRAM)	1	
020A	BICYCLE-0014	KZ999	•• Drive train system (SUPSDS ITEM 001) (REWORKED) (over the hills and far away) (FOR SELECT FROM PARTS REFER TO S1000DBIKE-D00-00-00-01-001)	1	
021A	BICYCLE-0014	KZ999	•• Drive train system (SUPSDS ITEM 001) (elsewhere) (REFER TO NHA S1000DBIKE- D00-00-00-01-001)	1	
022A	BICYCLE-0014	KZ999	•• Drive train system (SUPSDS ITEM 001) (long and winding road) (FOR DETAILS REFER TO S1000DBIKE-D00-00-00-01-001)	1	

ILLUSTRATED PARTS DATA

CTM23-10-10

2018-03-01

Page IPD-20

IPD figure D00-00-00-01A — Bicycle test bits

Item	Part number	MFR	Description	QNHA	UOC
023A	BICYCLE-0014	KZ999	•• Drive train system (SUPSDS ITEM 001) (neverwhere) (FOR ATTACHING PARTS REFER TO S1000DBIKE-D00-00-00-01-001)	1	
024A	BICYCLE-0014	KZ999	•• Drive train system (SUPSDS ITEM 001) (depends) (FOR OVERSIZE/UNDERSIZE PART REFER TO S1000DBIKE-D00-00-00-01-001)	1	
025A	BICYCLE-0014	KZ999	•• Drive train system (SUPSDS ITEM 001) (REF DES: FIN007)	1	
026A	BICYCLE-0015	KZ999	•• Brake sub-system (ORIGINAL PART NUMBER: AVLNO1234567890123456) (REF DES: FIN012 THRU FIN015)	1	
027A	BICYCLE-0015	KZ999	•• Brake sub-system (ORIGINAL PART NUMBER: AVLNO1234567890123456) (DELETED)	1	
028A	BICYCLE-0015	KZ999	•• Brake sub-system (ORIGINAL PART NUMBER: AVLNO1234567890123456) (ADDED)	1	
029A	BICYCLE-0015	KZ999	•• Brake sub-system (ORIGINAL PART NUMBER: AVLNO1234567890123456) (DIMENSIONAL PART DATA A0003)	1	
030A	BICYCLE-0015	KZ999	•• Brake sub-system (ORIGINAL PART NUMBER: AVLNO1234567890123456) (COMPUTER SOFTWARE)	1	
031A	BICYCLE-0015	KZ999	•• Brake sub-system (ORIGINAL PART NUMBER: AVLNO1234567890123456) (MOD A0005)	1	
032A	BICYCLE-0015	KZ999	•• Brake sub-system (ORIGINAL PART NUMBER: AVLNO1234567890123456) (A0006)	1	
033A	BICYCLE-0015	KZ999	•• Brake sub-system (ORIGINAL PART NUMBER: AVLNO1234567890123456) (MATCHED SET)	1	

COMPONENT MAINTENANCE PUBLICATION

S1000DBIKE-KD559-CMPXX-00

TEST

IPD figure D00-00-00-01A — Bicycle test bits

Item	Part number	MFR	Description	QNHA	UOC
034A	BICYCLE-0015	KZ999	•• Brake sub-system (ORIGINAL PART NUMBER: AVLNO1234567890123456) (MATCHED PART)	1	
035A	BICYCLE-0015	KZ999	•• Brake sub-system (ORIGINAL PART NUMBER: AVLNO1234567890123456) (ORDER NHA)	1	
036A	BICYCLE-0015	KZ999	•• Brake sub-system (ORIGINAL PART NUMBER: AVLNO1234567890123456) (ORDER PN A0009)	1	
037A	BICYCLE-0015	KZ999	•• Brake sub-system (ORIGINAL PART NUMBER: AVLNO1234567890123456) (TRUE PN A0010)	1	
038A	BICYCLE-0015	KZ999	•• Brake sub-system (ORIGINAL PART NUMBER: AVLNO1234567890123456) (PARTIAL BKDN)	1	
039A	BICYCLE-0015	KZ999	•• Brake sub-system (ORIGINAL PART NUMBER: AVLNO1234567890123456) (PROGRAMMED)	1	
040A	BICYCLE-0015	KZ999	•• Brake sub-system (ORIGINAL PART NUMBER: AVLNO1234567890123456) (UNPROGRAMMED)	1	
041A	BICYCLE-0015	KZ999	•• Brake sub-system (ORIGINAL PART NUMBER: AVLNO1234567890123456) (USED ON ITEM A0014)	1	
042A	BICYCLE-0015	KZ999	•• Brake sub-system (ORIGINAL PART NUMBER: AVLNO1234567890123456) (USED WITH ITEM A0015)	1	
043A	BICYCLE-0015	KZ999	•• Brake sub-system (ORIGINAL PART NUMBER: AVLNO1234567890123456) (USED ON PN A0016)	1	A, B, C, D, E, F, G, H
044A	BICYCLE-0015	KZ999	•• Brake sub-system (ORIGINAL PART NUMBER: AVLNO1234567890123456) (USED WITH PN A0017)	1	

ILLUSTRATED PARTS DATA

CTM23-10-10

2018-03-01

Page IPD-22

COMPONENT MAINTENANCE PUBLICATION

S1000DBIKE-KD559-CMPXX-00

TEST

IPD figure D00-00-00-01A — Bicycle test bits

Item	Part number	MFR	Description	QNHA	UOC
045A	BICYCLE-0015	KZ999	•• Brake sub-system (ORIGINAL PART NUMBER: AVLNO1234567890123456) (SPARES ONLY)	1	A, B
046A	BICYCLE-0015	KZ999	•• Brake sub-system (ORIGINAL PART NUMBER: AVLNO1234567890123456) (LIFE LIMITED PART)	1	B

End of S1000DBIKE-AAA-D00-00-00-02AA-941A-D

End of DETAILED PARTS DATA

End of ILLUSTRATED PARTS DATA

INTENTIONALLY BLANK